



INSTALLATION INSTRUCTIONS

PRO TRAX[®] 5 WHEEL-TO-WHEEL

AUTOMOTIVE PRODUCTS,

APPLICATION:
2007-2015 Toyota Tundra D-Cab 6.5 ft Bed
PART NUMBER: 21-534170, 21-534175

ITEM	QUANTITY	DESCRIPTION	TOOLS NEEDED
1,2	2	STEP BAR ASSEMBLY DRIVER/PASSENGER	13MM SOCKET
3	2	FRONT MOUNTING BRACKET	TORQUE WRENCH
4	2	MIDDLE MOUNTING BRACKET	RATCHET
5	2	REAR MOUNTING BRACKET	12MM SOCKET
6	12	M8 HEX HEAD CAP SCREW (YELLOW ZINC)	19MM SOCKET
7	12	M8 FLAT WASHER (YELLOW ZINC)	HEX KEY
8	12	M8 SPRING LOCK WASHER (YELLOW ZINC)	
9	12	M10 HEX BUTTON HEAD SOCKET CAP SCREW (BLACK ZINC)	
10	12	M10 FLAT WASHER (BLACK ZINC)	
11	12	M10 INTERNAL TOOTHED LOCK WASHER (BLACK ZINC)	

ANTI-SEIZE LUBRICANT MUST BE USED ON ALL STAINLESS STEEL FASTENERS TO PREVENT THREAD DAMAGE AND GALLING

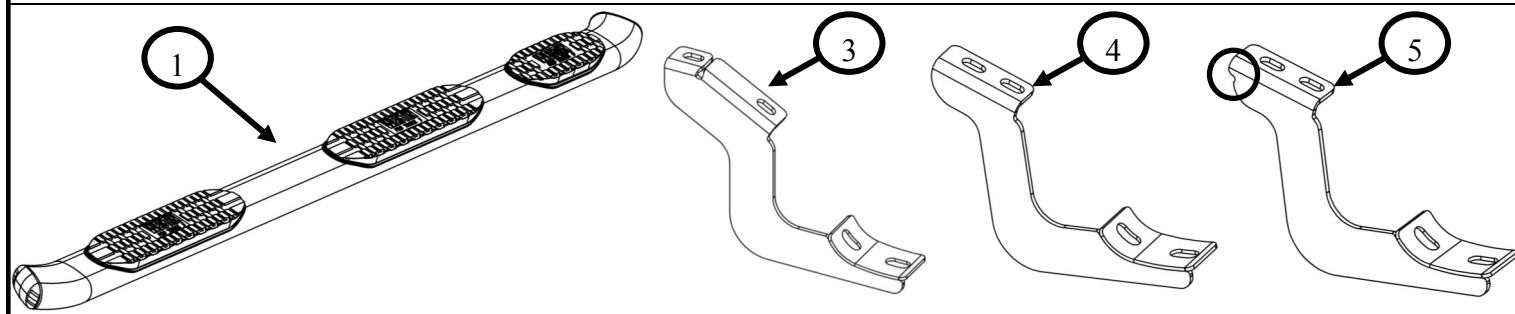

PROCEDURE

- Remove contents from box, verify if all parts listed are present and free from damage. Carefully read and understand all instructions before attempting installation.
Failure to identify damage before installation could lead to a rejection of any claim.
- Start installation on the driver's side. On the rocker panel, find locations of factory bolts. Remove factory hardware and discard. (Note: Brackets will be installed in these locations with provided hardware.) **See Fig. 1 & 2.**
- Locate Front, Middle, and Rear Mounting Brackets (Items 3, 4, 5). Using the supplied M8 hardware, loosely install the brackets to the rocker panel. **See Fig. 3, 4, & 5.** (Note: Item 5 has a notch to differentiate from Item 4. See image above.)
- Locate the Driver Step Bar Assembly (Item 1) and align it with the brackets. **See Fig. 6.**
- Loosely install the Driver Step Bar Assembly using supplied M10 hardware. **See Fig. 7.**
- Align and adjust the step bar and brackets as necessary then tighten and torque all fasteners as follows: M8 to 20 ft-lbs, M10 30 ft-lbs.
- Repeat for the passenger side.



Westin Automotive Products, Inc.
 320 W. Covina Blvd
 San Dimas, Ca. 91773

Thank You for choosing Westin products
 For Additional installation assistance please call
 Customer service (800) 793-7846
 www.westinautomotive.com

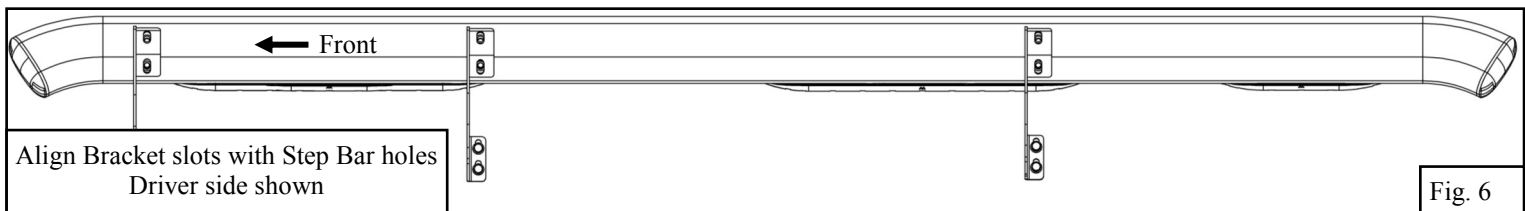
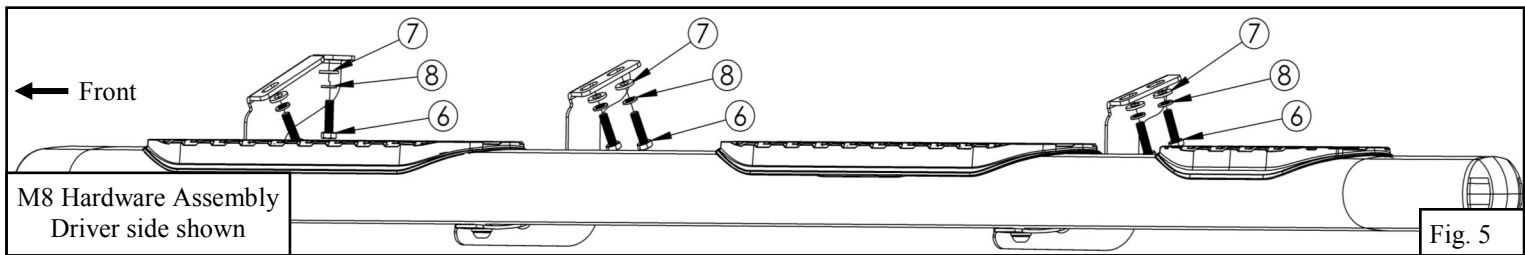
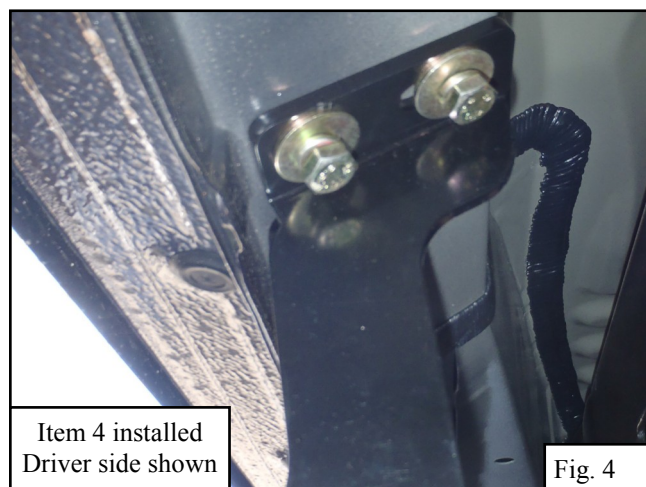
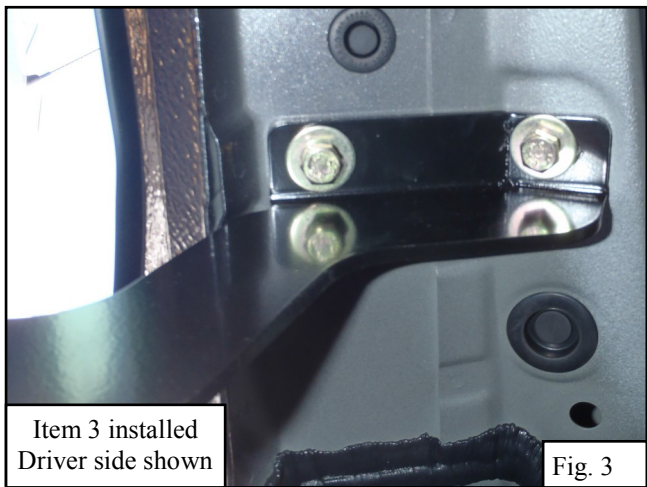
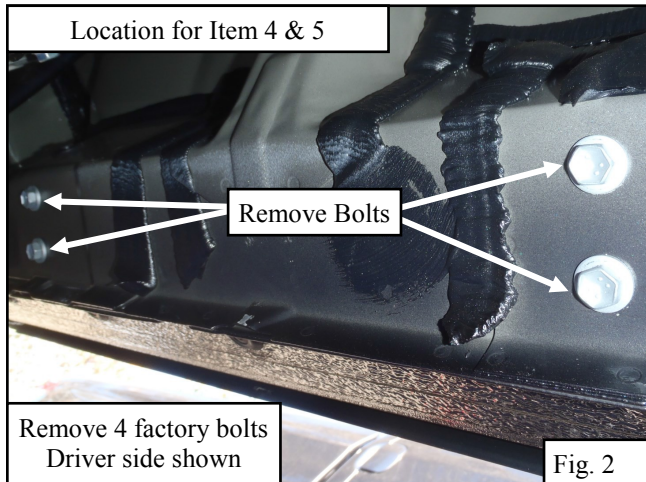
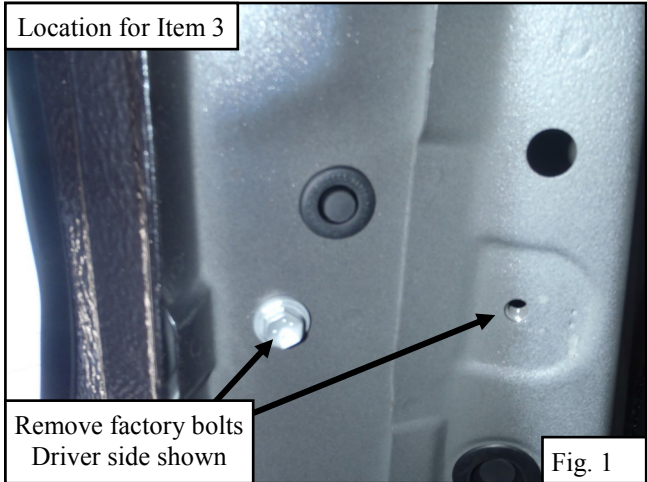

Westin Automotive Products, Inc.
320 W. Covina Blvd
San Dimas, Ca. 91773

Thank You for choosing Westin products
For Additional installation assistance please call
Customer service (800) 793-7846

M10 Hardware Assembly
Driver side shown

Fig. 7

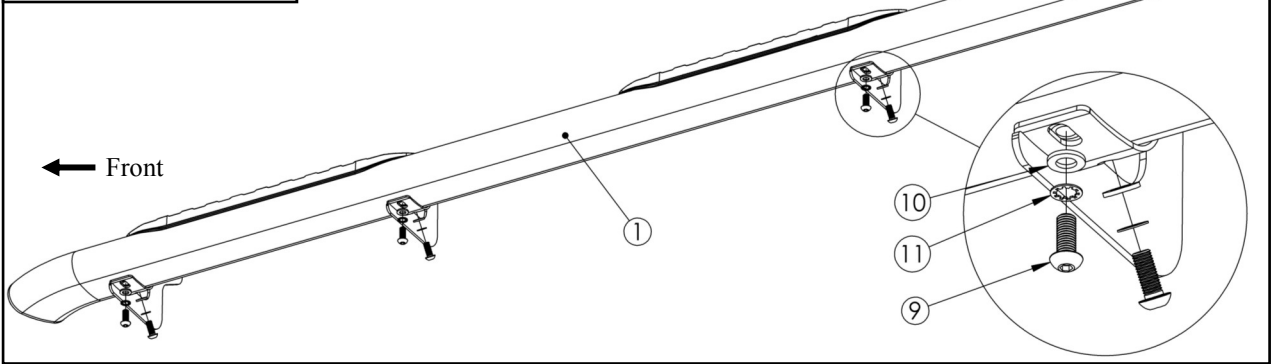

CARE INSTRUCTIONS

- REGULAR WAXING IS RECOMMENDED. DO NOT USE ANY TYPE OF POLISH OR WAX THAT MAY CONTAIN ABRASIVES.
- STAINLESS STEEL PRODUCTS CAN BE CLEANED WITH MILD SOAP AND WATER. STAINLESS STEEL POLISH SHOULD BE USED TO POLISH SMALL SCRATCHES.
- GLOSS BLACK FINISHES SHOULD BE CLEANED WITH MILD SOAP AND WATER.



Westin Automotive Products, Inc.
320 W. Covina Blvd
San Dimas, Ca. 91773

Thank You for choosing Westin products
For Additional installation assistance please call
Customer service (800) 793-7846
www.westinautomotive.com