

TOYOTA TUNDRA 2022+ OWNER'S SUPPLEMENT

FOLLOW STEP 1 OF THE MAIN OWNER'S MANUAL THEN USE THIS SUPPLEMENT TO INSTALL THE UNDERBODY RAILS, SIDE RAILS AND CLAMPS

It is important that all areas where the bed cover mounts are clean and free of debris prior to installing.

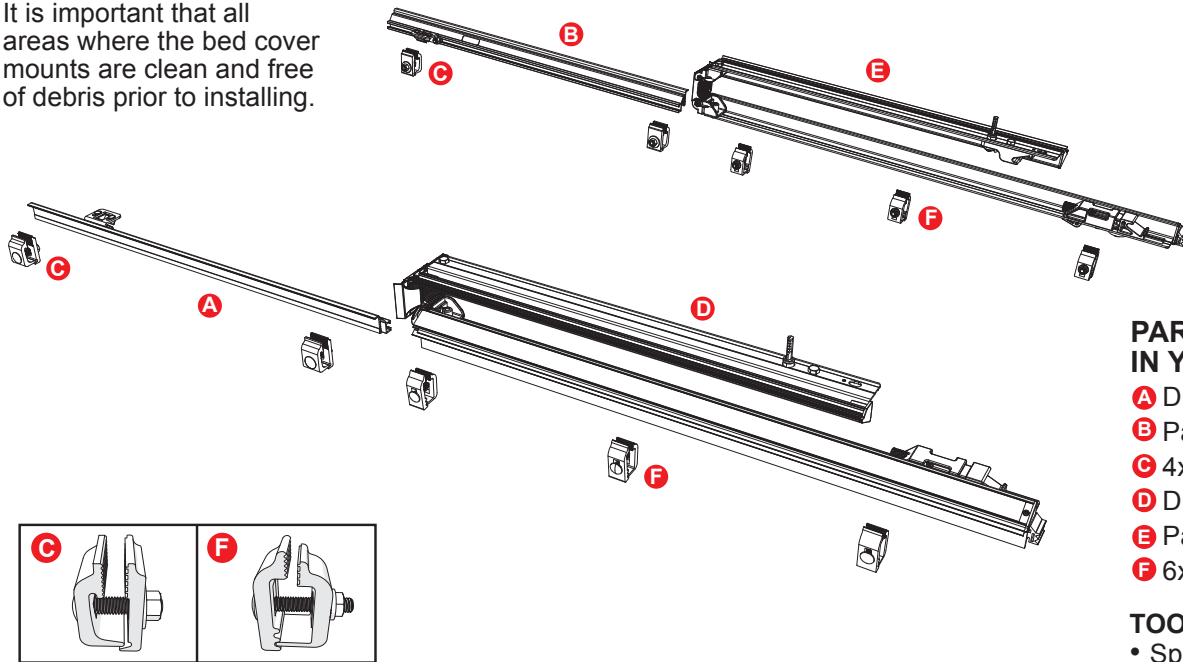

PARTS INCLUDED IN YOUR KIT:

- A** Driver side underbody rail
- B** Passenger underbody rail
- C** 4x Underbody clamps
- D** Driver side rail
- E** Passenger side rail
- F** 6x Side rail clamps

TOOLS RECOMMENDED

- Spring clamps

1 UNDERBODY RAIL INSTALLATION

Position the driver side underbody rail (A) against the truck's bed rail near the cab. Place 2 underbody clamps (C) evenly spaced along the underbody rail. Finger tighten only. Repeat on passenger side underbody rail (B).

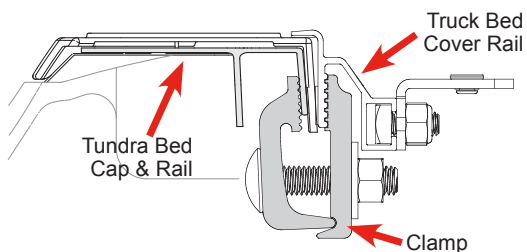
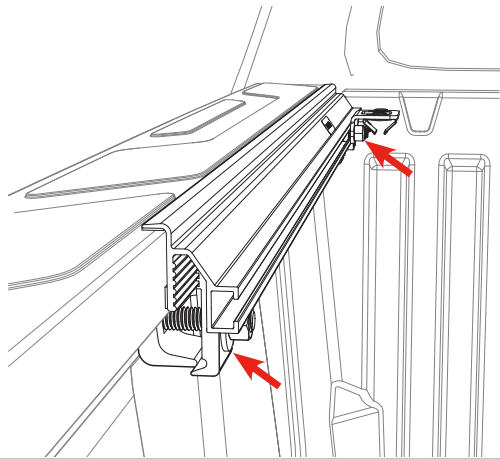

2 SIDE RAIL INSTALLATION

Next position the driver side rail (D) against the truck's bed rail. Begin clamping the driver side rail to the truck bed. Start in the middle and evenly space 3 side rail clamps (F) along the rail. Leave approximately 8" on each end of the rail. Finger tighten the clamps, making sure the teeth properly engage with the grooves of the side rail. Repeat on the passenger side rail (E).

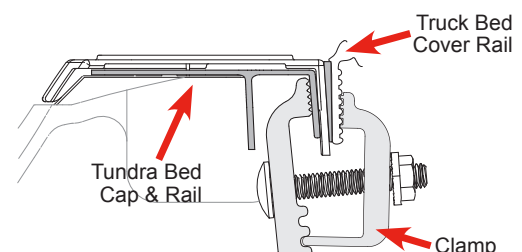
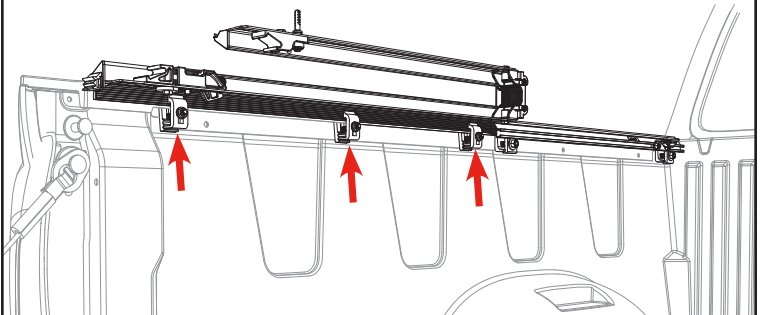

RETURN TO THE MAIN OWNER'S MANUAL FOR RAIL ADJUSTMENTS AND FINAL CLAMP TIGHTENING