

# Raptor Series



**Your satisfaction is important to us, please let us help!**

If you have any questions or concerns during the installation, our support representatives are available to assist you.

Please call: 1-877-769-3765 or Live Chat at [www.raptorseries.com](http://www.raptorseries.com)

If you have damaged or missing parts please contact the company you purchased the product from and notify them of the issue right away.



**CAUTION: Do not install damaged parts!!!**

# Raptor Series

## Easy Return / Easy Exchange

---

### **Want to return an item or exchange? Not satisfied with purchase?**

No problem. We strongly believe in service after the sale and we stand behind our products and our service to you, our valued customer. There is no problem we can't solve for you!

Items that have been installed and/or damaged after receipt, are no longer in new and ready-to-sell condition and cannot be refunded, replaced or exchanged unless it has a manufacturer defect or was damaged in shipping. In addition, we cannot accept return on items that are not in the original packaging. Items returned in poor condition or having parts missing will not be credited.

**Please note: Your request for return or replacement must be initiated within 30 days of delivery of your merchandise.**

### **Did your order arrive damaged?**

Please do not install damaged products. Contact the company you purchased your product from as soon as possible and notify them of the damages. They will make arrangements with you to assist with the problem.

### **Did you order the wrong part or receive the wrong item?**

Don't worry. From time to time human error can result in problems with ordering or shipping. Contact the company you purchased your product from as soon as you notice the error. Every company has their own policy on returning parts that have been ordered incorrectly or shipped incorrectly.

In the event that you need to ship your part back to return/exchange, please ship to the warehouse below:

**CYC Returns Warehouse  
2415 Cathy Lane  
Jasper, IN 47546**

The logo for the Raptor Series, featuring the word "Raptor" in a green, stylized script font and the word "Series" in a black, bold, sans-serif font below it. The background of the logo is a light green silhouette of a raptor in flight.

# Raptor Series

## Raptor Series Warranty

### LIMITED TEN (10) YEAR WARRANTY

#### For Powder Coated Steel Products

CYC Engineering, Inc. guarantees the original purchaser of our products a limited ten (10) year warranty from the date of original purchase against manufacturer defects in materials, workmanship and finish under normal use. The step pads are covered under warranty for 1 year. This warranty does not include damage resulting from road hazards such as gravel or other debris, product misuse, improper installation, impairments from accidents, product modifications, product neglect or scratches during the life of the product. This limited ten year warranty applies only to new products and is limited to the repair or replacement of company's products. Warranty does not include costs of removal, installation, labor, inconvenience or consequential damages. Original purchaser must return defective merchandise along with the purchase receipt, to the original place of purchase.

### LIMITED LIFETIME WARRANTY

#### For Stainless Steel Products

CYC Engineering, Inc. guarantees the original purchaser of our products a limited lifetime warranty from the date of original purchase against manufacturer defects in materials, workmanship and finish under normal use. The step pads are covered under warranty for 1 year. This warranty does not include damage resulting from road hazards such as gravel or other debris, product misuse, improper installation, impairments from accidents, product modifications, product neglect or scratches during the life of the product. This limited lifetime warranty applies only to new products and is limited to the repair or replacement of company's products. Warranty does not include costs of removal, installation, labor, inconvenience or consequential damages. Original purchaser must return defective merchandise along with the purchase receipt, to the original place of purchase.

1301-0151

# RUNNING BOARD



## Components:

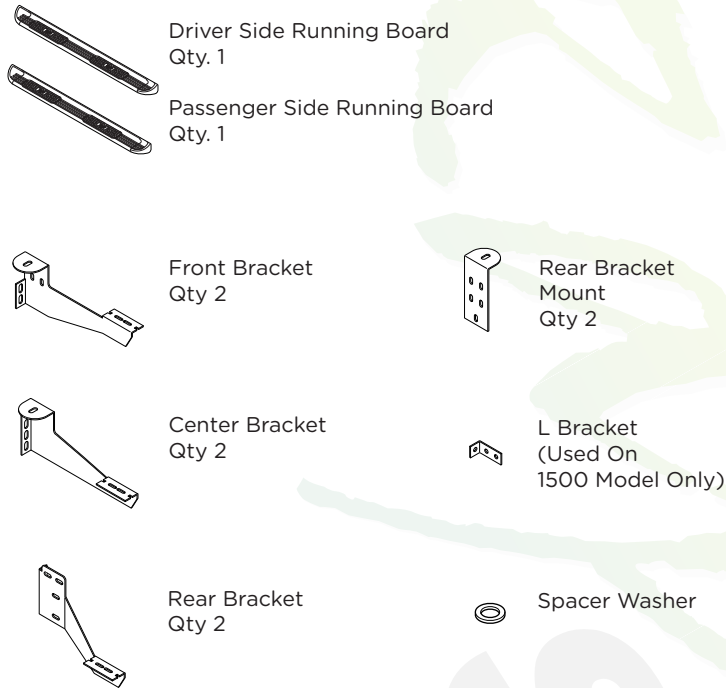

## Hardware:

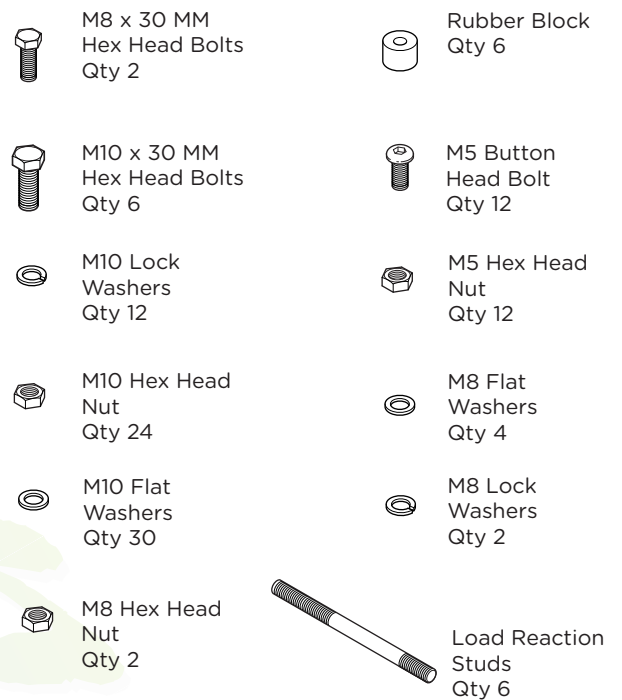

## Tools Required:

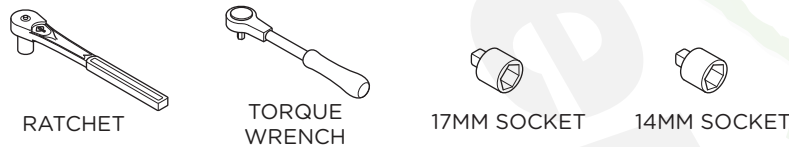

## Torque Specifications:

For Cab Mount Installations

Cab mount bolts are torqued to 70 Ft Lbs. All other M8 through M12 sized bolts/nuts are set to 15-20 ft lbs.

**Note: When installing the brackets and bars, all hardware must be left loose until all the items are attached.**

1. Remove all contents from the package and check stainless steel running boards for any damage. Also, verify that all components and hardware listed above are included before you begin installation.
2. Read installation manual and installation drawing completely. Understand all brackets and bolts before installation.

**3.** Begin installation on driver side. Position drivers side Front Bracket, Center Bracket and Rear Bracket as shown along driver side.

Assemble the Load Reaction Studs as follows:

**4a.** On the short threaded end of the Load Reaction Stud, install a M10 Hex Head Nut, a M10 Flat Washer to the bottom of thread, then install a Rubber Block tight up against the M10 Washer and the M10 Hex Head Nut. (The end of the Stud must be recessed in the rubber washer approximately 3/16").

**4b.** On the long threaded end of the Load Reaction Stud, install a M10 Flat Washer, a M10 Lock Washer and a M10 Hex Head Nut to the bottom of the threads.

**NOTE: IF MOUNTING THE RUNNING BOARD ON A 1500 MODEL TRUCK. YOU MUST ATTACH L BRACKET TO FRONT BRACKET IN ORDER TO USE THE LOAD REACTION STUD.**

**5.** Remove the factory front, center and rear cab mount bolts and install the mount brackets and running board per following instruction.

**6.** Install the Brackets to the Cab Mounts as shown. Hand tighten, until the Load Reaction Stud and the Running Board has been installed.

**7.** Attach the load reaction stud assemblies to the mounting brackets as shown. Insert the stud from what will be in the inboard or frame side thru the lowest hole in the bent flange of the bracket that will allow the rubber washer to seat firm against the side wall of the frame. Install a M10 flat washer, a M10 lock washer and a M10 Hex Head Nut (Hand tight only)

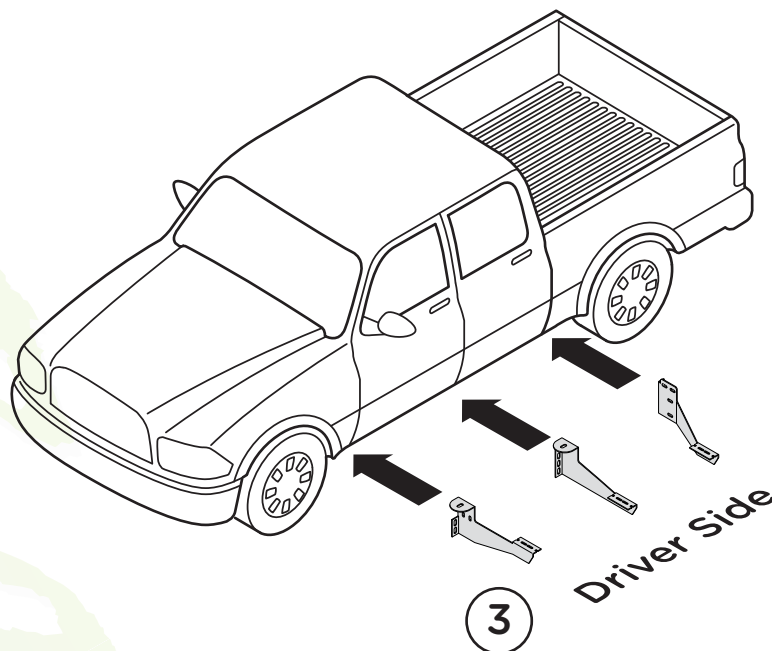

**8.** Attach the Running Board to the Front, Center and Rear Brackets using M5 Button Head Bolts and M5 Hex Head Nuts.

**9.** Repeat these steps for passenger side installation. When all hardware is in place, everything must be tightened. See Page 1 for Torque Specifications.

