

S7213

2015 up MUSTANG GT RESONATOR
DELETE

MBRP®

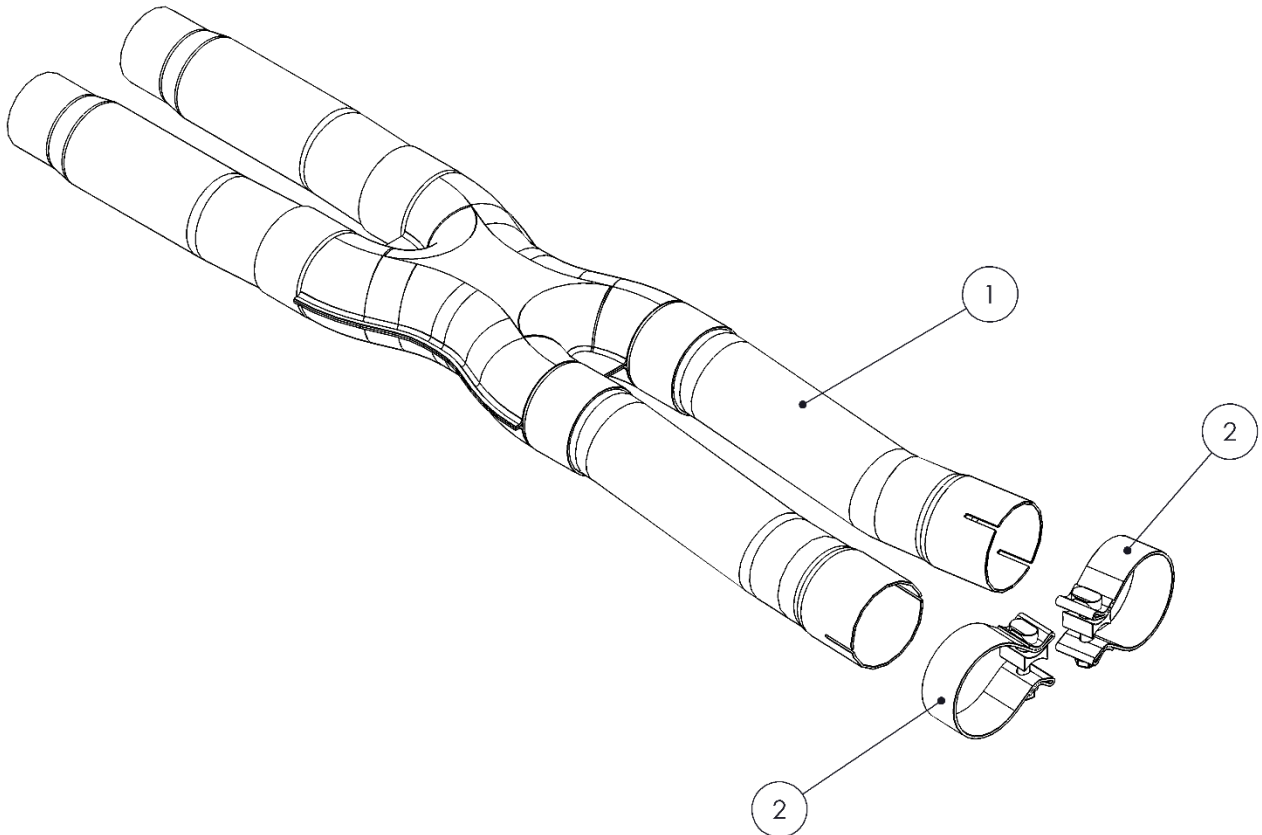

1. RESONATOR DELETE ASSEMBLY
2. 2.5" CLAMP [2 PCS]

PLEASE READ BEFORE STARTING INSTALLATION

While MBRP Inc. has made every effort to ensure that all components of this system are of superior quality and properly packaged, it is the installer's responsibility to ensure the following before removal of the factory exhaust:

- that ALL components shown above are present.
- that ALL mating components fit together.
- that there are no damaged components.
- that the system you have purchased is appropriate for your vehicle year, model and configuration.
- that the system will not interfere with any modifications previously installed or planned.
- that you have read and understand these instructions.

If you have any questions or are uncertain about any aspect of the installation of this system to your vehicle please contact your dealer before commencing installation.

Removal of Stock System



Figure 1



Figure 2

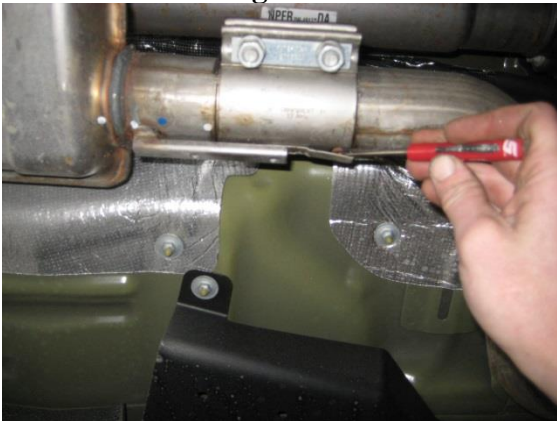

Figure 3



Figure 4

1. Apply a penetrating lubricant liberally to all exhaust fasteners, hangers and rubber insulators.

2. Remove the 2 piece undercar brace. [Convertible Only]
Refer to Figure 1.

3. Remove the M8 bolts from the mid hanger brackets and remove them from the vehicle. Retain these parts as they will be reused.

Refer to Figure 2.

4. Loosen both clamps ahead of the resonator, lift the lock tabs and slide the clamps rearward to disconnect the OEM catback from the front section of the exhaust. Use caution, The OEM catback is one piece and heavy.

Refer to Figure 3.

5. Remove the OEM catback by lowering the inlet end and sliding the assembly forward to remove it from the rear hangers. Remove the OEM clamps as they will be reused.

6. Unbolt and remove the rear hanger brackets. Retain these parts, they will be reused.

Installation of MBRP Performance Exhaust

1. Lay the **Resonator Delete Assembly** on top of the OEM Cat Back being sure the inlets are aligned with each other. Note that the passenger-side outlet has more bend angle than the driver-side outlet. Transfer marks from the end of the **Resonator Delete Assembly** to the OEM Catback.

Refer to Figure 4.

2. Measure 2" Forward of the marks made in step 1 and scribe a cut line on the OEM pipes. The cut lines should be at the end of the straight section of pipe right next to the bends exiting the OEM Resonator. Using a sawsall or similar tool, cut and deburr the OEM pipes.

Refer to Figures 5 and 6.



Figure 5



Figure 6



Figure 7



Figure 8

3. Reusing the original clamps, install the **Resonator Delete Assembly** being sure that the outlet with more bend angle is located on the passenger side of the car. Ensure the Assembly is installed level as viewed from the rear and tighten the clamps.

Refer to Figure 7.

4. Install a **2.5" Clamp** onto the passenger side outlet of the **Resonator Delete Assembly**. Reinstall the passenger-side of the OEM catback using the previously removed mid and rear hanger brackets.

Refer to Figure 8.

5. Reinstall the driver-side of the OEM catback using the procedure illustrated in step 4.

6. Install the undercar brace [Convertible Only] using the previously removed hardware.

7. Align the exhaust and tighten all clamps.

8. Align the edge of each band clamp with the edge of the joint it is connecting. Tighten all hardware and clamps, starting at the front and working rearward to secure the system. Check along the full length of the exhaust system to ensure there is adequate clearance for fuel lines, vent lines, brake lines, frame, bodywork, suspension, and any wiring, etc. If there is any interference detected, relocate, or adjust to provide adequate clearance. Ensure all clamp connections are secure and components are unable to rotate or slide. Band clamps require approximately 45 lb-ft (60 N-m) of torque. Verify clearances, system security and band clamp torque after 30-60 miles (50-100 km) of driving.

Congratulations! You are ready to begin experiencing the improved performance and driving pleasure of your **MBRP** performance exhaust system. We know you will enjoy your purchase.