

S61140

2003-2004 DODGE 2500/3500, 5.9L CUMMINS
TURBO BACK, 5", SINGLE SIDE,
NOT FOR USE ON VEHICLES WITH CATALYTIC
CONVERTER

MBRP®

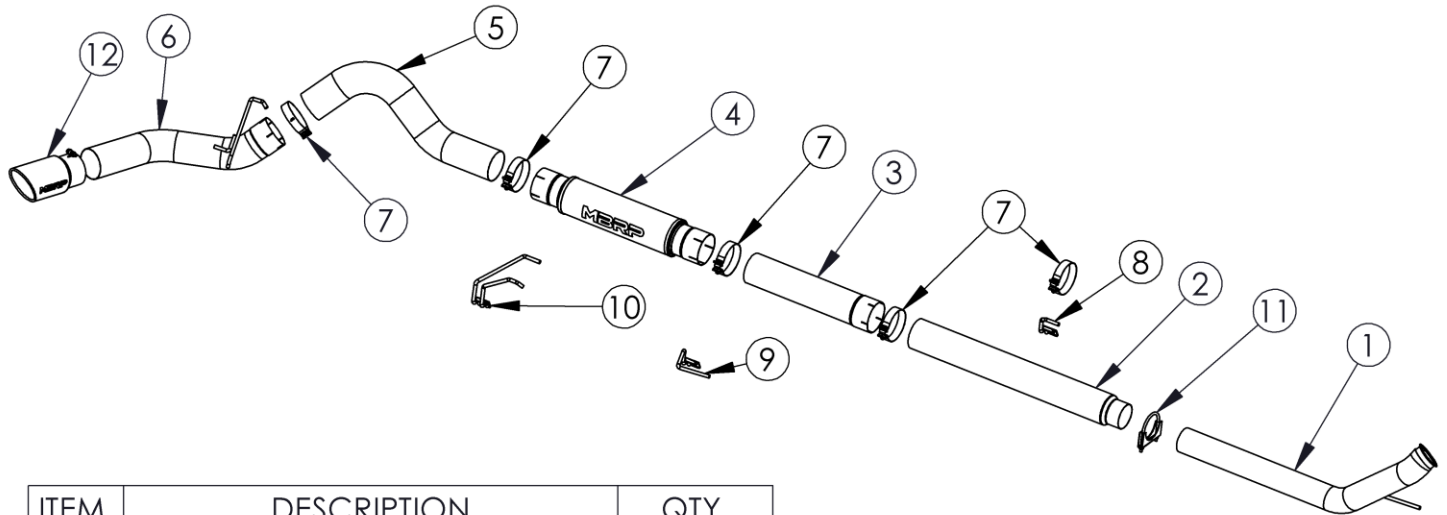

ITEM	DESCRIPTION	QTY.
1	DOWN PIPE	1
2	4" TO 5" EXTENSION PIPE - 59"	1
3	MID PIPE	1
4	MUFFLER	1
5	OVER-AXLE PIPE	1
6	TAIL PIPE	1
7	5" BAND CLAMP	5
8	HANG TIGHT™ HANGER	1
9	HANG TIGHT™ HANGER	1
10	DUAL HANG TIGHT™ HANGER	1
11	4" CLAMP	1
12	EXHAUST TIP	1

PLEASE READ BEFORE STARTING INSTALLATION

While MBRP has made every effort to ensure that all components of this system are of superior quality and properly packaged, it is the installer's responsibility to ensure the following before removal of the factory exhaust:

- that ALL components shown above are present.
- that ALL mating components fit together.
- that there are no damaged components.
- that the system you have purchased is appropriate for your vehicle year, model and configuration.
- that the system will not interfere with any modifications previously installed or planned.
- that you have read and understand these instructions.

If you have any questions or are uncertain about any aspect of the installation of this system to your vehicle please contact your dealer before commencing installation.

MBRP

Removal of stock system:

1. Apply a penetrating lubricant liberally to all exhaust fasteners, hangers, and rubber insulators.
2. Remove the exhaust system from the rubber insulators and remove all the clamps from the system.
3. Separate the slip joint behind the muffler and remove the tail pipe. Next, separate the slip joint connecting the down pipe and the extension pipe to remove the muffler and extension pipe. Now loosen the band clamp connecting the down pipe to the turbo and remove the down pipe. Do not discard the band clamp as it is required for the installation.
4. Remove the spare tire. You may not be able to reinstall your spare tire after the installation of this exhaust system.

Installation of MBRP Performance Exhaust:

1. Install the Down Pipe in the same position as the stock down pipe by sliding the hanger into the OEM hanger bracket and then attaching the flared end to the turbo using the stock band clamp. Do not fully tighten until all components are in place.
2. Install the **4" to 5" Extension Pipe** over the **Down Pipe** using the **4" Clamp** provided. The **4" to 5" Extension Pipe** provides the required length to fit a **Quad Cab Long Bed** truck. The **4" to 5" Extension Pipe** will have to be cut to fit all other vehicles.

Installation Tip: Temporarily install the Muffler, Mid Pipe and Tail Pipe using the factory rubber insulators and the **Hang Tight™ Hanger clamps**. Measure from the Mid Pipe to the Down Pipe to determine the length required. Ensure that you leave 6" (3" each end) for the joints to overlap. Cut the Extension Pipe to the required length.

3. Install the **Hang Tight™ Hangers** onto **5.0" Band Clamps** using the procedure shown below. (Hang Tight™ Hangers not exactly as shown).

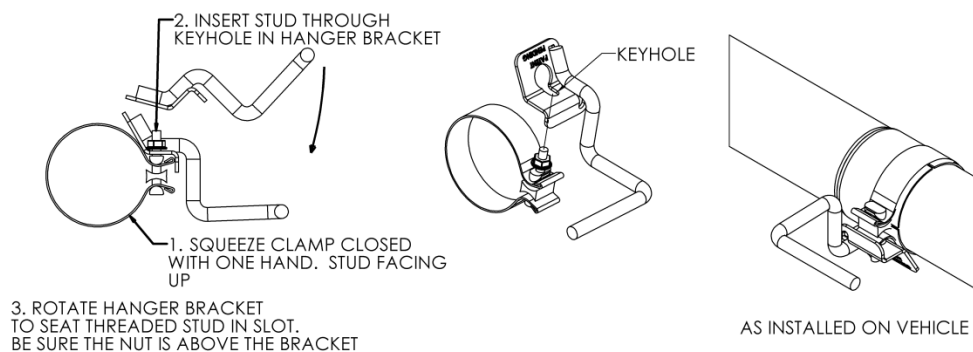

4. Install the front single **Hang Tight™ Hanger Clamp Assembly** (shortest hanger) onto the **4" to 5" Extension Pipe** and into the factory rubber insulator located on the frame.
5. Install the **Mid Pipe** over the **Extension Pipe** using the **5" Clamp** provided.

MBRP

6. Install the **High Flow Muffler** onto the **Mid Pipe** using the second single **Hang Tight™ Hanger Clamp Assembly**. **Refer to the image at right for optimal muffler orientation**. Install the Hanger into the factory rubber insulator.
7. Install the **Dual Hang Tight™ Hanger Clamp Assembly** onto the outlet of the **High Flow Muffler**. Install the hangers into the two OEM rubber hangers located above the outlet of the **High Flow Muffler**.
8. Remove the factory rubber insulator for the factory tail pipe and install it onto the **Tail Pipe** hanger. Install the **Tail Pipe** and **5" Band Clamp** onto the **Over-Axle Pipe**. From the rear of the truck, slide the assembly over the axle and attach to the outlet of the **High Flow Muffler**. Finish hanging the **Tail Pipe**.
9. Adjust the **Tail Pipe** and install and adjust the **Exhaust Tip** to suit. Tighten the lock bolt located on the **Exhaust Tip**.
10. Tighten all hardware and clamps, starting at the front and working rearward to secure the system. Check along the full length of the exhaust system to ensure there is adequate clearance for fuel lines, vent lines, brake lines, frame, bodywork, suspension, and any wiring, etc. If there is any interference detected, relocate, or adjust to provide adequate clearance. Ensure all clamp connections are secure and components are unable to rotate or slide. Band clamps require approximately 45 lb-ft (60 N-m) of torque. Verify clearances, system security and band clamp torque after 30-60 miles (50-100 km) of driving.

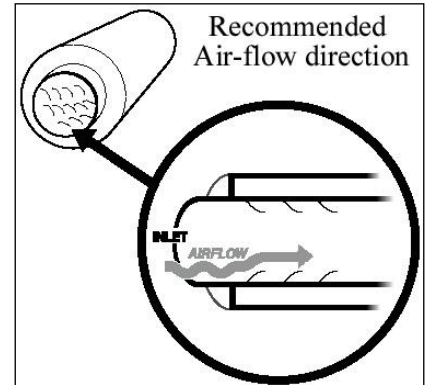

Congratulations! You are ready to begin enjoying the improved performance and driving experience of your **MBRP** performance exhaust system. We hope you enjoy your purchase.