

S6104P

03-04 DODGE 2500/3500 5.9L CUMMINS, TURBO BACK, 4" SINGLE SIDE
NOT FOR USE ON VEHICLES EQUIPPED WITH CATALYTIC CONVERTER

MBRP

21-Dec-2020

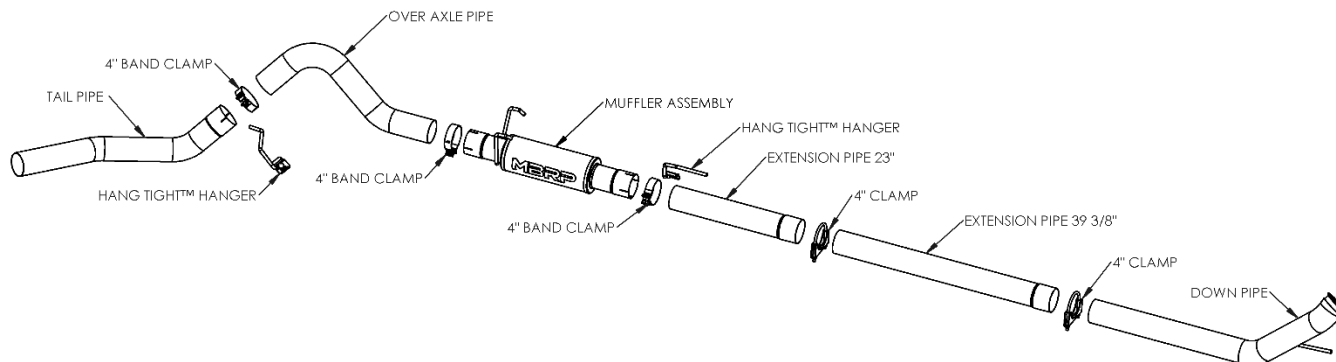

PLEASE READ BEFORE STARTING INSTALLATION

MBRP Inc. has made every effort to ensure that all components of this system are of superior quality and properly packaged. It is the installer's responsibility to ensure that all components are present and fit together as shown. Please also ensure that all components are undamaged before removal of the factory exhaust. Finally check that this system properly matches the make and model of the vehicle and will not interfere with previous or planned modifications.

Removal of stock system:

1. Apply a penetrating lubricant liberally to all exhaust fasteners, hangers and rubber insulators.
2. Remove the exhaust system from the rubber insulators and remove all of the clamps from the system.
3. Separate the slip joint behind the muffler and remove the tail pipe. Next, separate the slip joint connecting the down pipe and the extension pipe to remove the muffler and extension pipe. Finally loosen the band clamp connecting the down pipe to the turbo and remove the down pipe. **Do not discard the band clamp as it is required for the installation.**

Installation of MBRP Ltd. Performance Exhaust:

1. Install the **Down Pipe** in the same position as the stock down pipe by sliding the hanger into the **OEM** hanger bracket and then attaching the flared end to the turbo using the stock band clamp. Do not fully tighten until all components are in place.
2. Install the **Extension Pipe 39 3/8"** over the **Down Pipe** using **4" Clamp**. The **Extension Pipe 23"** is also required for the **Quad Cab Long Bed**. The **Extension Pipe 39 3/8"** may require cutting to accommodate vehicles other than the **Quad Cab long bed**. (Installation tip: Temporarily hang the muffler in place using the OEM rubber hangers and measure from the muffler to the down pipe to determine the length required). Install the **Extension Pipe 23"** onto the **Extension Pipe 39 3/8"** using **4" Clamp**. Do not fully tighten the clamp yet.
3. Install the **Hang Tight™ Hanger** onto a **4" Band Clamp** using the procedure shown below. (**Hang Tight™** Hanger not exactly as shown).

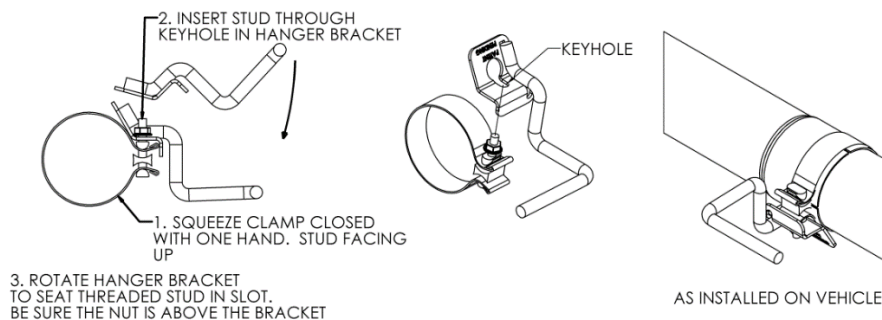

MBRP[®]

4. Install the **Muffler** onto the **Extension Pipe 23"** using the **Hang Tight™ Hanger** assembly. Install the **Muffler** hangers into the two OEM rubber insulators located above the outlet of the **Muffler**. Do not fully tighten the clamp yet.
5. Install the **Over Axle Pipe** into the end of the **Muffler** using the **4.0" Band Clamp**. Do not fully tighten the clamp yet.
6. Install the **Hang Tight™ Hanger** onto a **4" Band Clamp** using the procedure shown above. (Hang Tight™ Hanger not exactly as shown). Install the **Tail Pipe** onto the end of the **Over Axle Pipe** using the **Hang Tight™ Hanger** assembly and Insert the hanger into the factory rubber insulator. Do not fully tighten the clamp yet.
7. Align the edge of each band clamp with the edge of the joint it is connecting. Tighten all hardware and clamps, starting at the front and working rearward to secure the system. Check along the full length of the exhaust system to ensure there is adequate clearance for fuel lines, vent lines, brake lines, frame, bodywork, suspension, and any wiring, etc. If there is any interference detected, relocate, or adjust to provide adequate clearance. Ensure all clamp connections are secure and components are unable to rotate or slide. Band clamps require approximately 45 lb-ft (60 N-m) of torque. Verify clearances, system security and band clamp torque after 30-60 miles (50-100 km) of driving.

Congratulations! You are ready to begin experiencing the improved performance and driving excitement of your **MBRP Ltd.** performance exhaust system. We know you will enjoy your purchase.