

S5342

2004-UP TOYOTA 4-RUNNER 4.0L, 2011-2016
LAND CRUISER PRADO, CAT BACK, 2.5"
SINGLE REAR EXHAUST

MBRP®

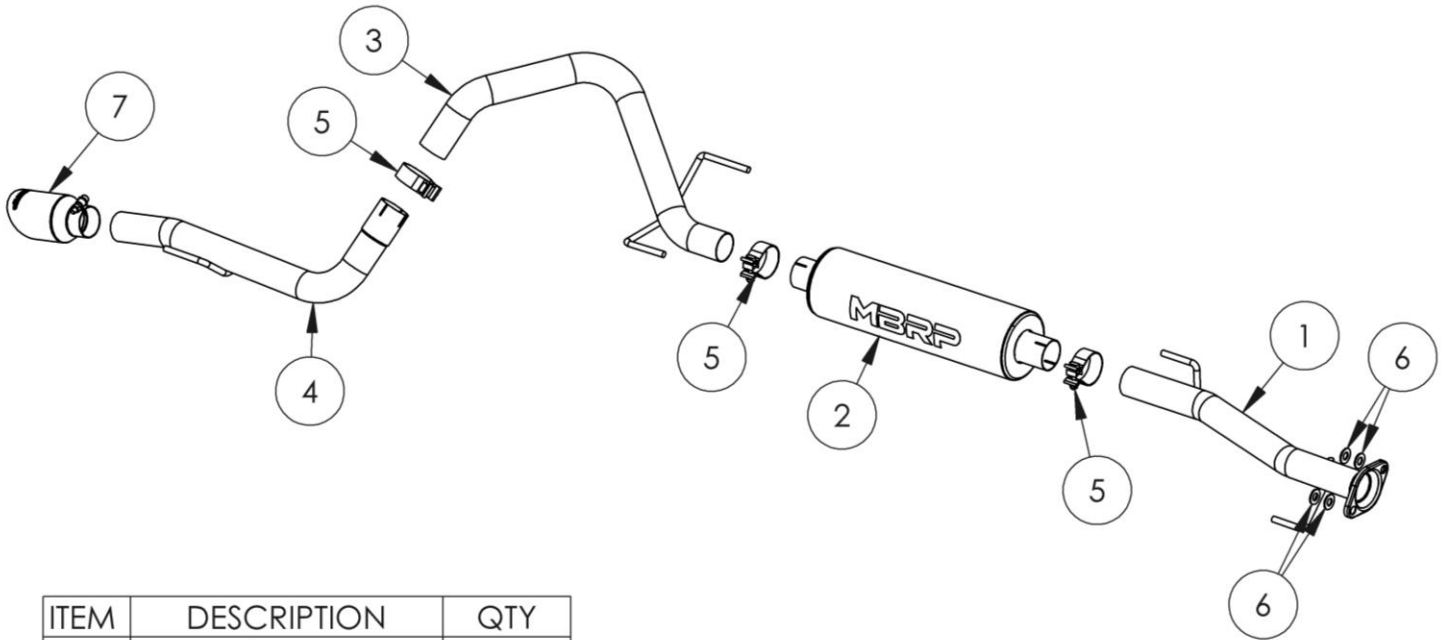

ITEM	DESCRIPTION	QTY
1	FRONT PIPE	1
2	MUFFLER	1
3	OVER-AXLE PIPE	1
4	TAIL PIPE	1
5	2.5" CLAMP	3
6	5/8" FLAT WASHER	4
7	TIP	1

PLEASE READ BEFORE STARTING INSTALLATION

While MBRP has made every effort to ensure that all components of this system are of superior quality and properly packaged, it is the installer's responsibility to ensure the following before removal of the factory exhaust:

- that ALL components shown above are present.
- that ALL mating components fit together.
- that there are no damaged components.
- that the system you have purchased is appropriate for your vehicle year, model and configuration.
- that the system will not interfere with any modifications previously installed or planned.
- that you have read and understand these instructions.

If you have any questions or are uncertain about any aspect of the installation of this system to your vehicle please contact your dealer before commencing installation.

MBRP

Removal of Stock System

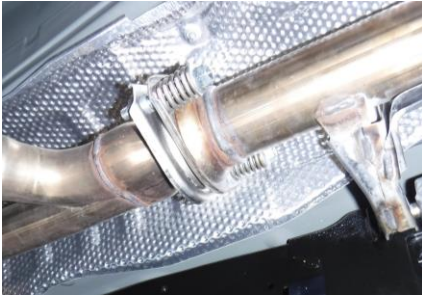

Figure 1



Figure 2

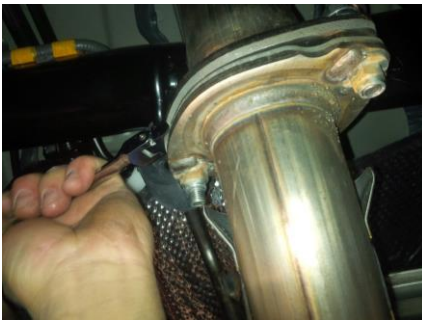

Figure 3

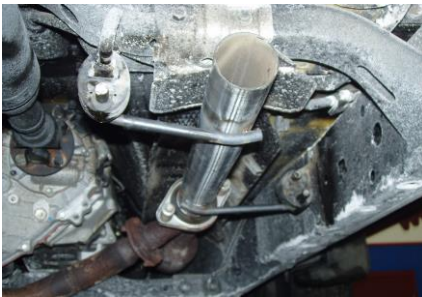

Figure 4



Figure 5

1. Apply a penetrating lubricant liberally to all exhaust fasteners, hangers, and rubber insulators.

2. Remove the bolts and springs holding the front flange together and disconnect the exhaust system. Do not discard this hardware; it will be reused during the installation.

Refer to Figure 1.

3. Remove the hardware from the flange behind the muffler, then remove the rear hanger from the rubber insulator and remove the tail pipe from the vehicle. Removing the spare-tire heat shield will make removing the tail pipe easier.

Refer to Figures 2 & 3.

4. Remove the muffler and front pipe hangers from the rubber insulators and remove the exhaust from the vehicle.

Installation of MBRP Performance Exhaust

1. Slide two of the **5/8" Flat washers** over the bolts previously removed from the flange and then slide the springs over the bolts. Now, loosely attach the **Front Pipe** to the flange using the fasteners.

Refer to Figure 4.

2. Install the muffler onto the **Front Pipe** using a **2.5" Clamp**. Do not fully tighten the clamp yet.

Refer to Figure 5.

3. Slide a **2.5" Clamp** over the outlet side of the Muffler. Position the **Over-Axle Pipe** over the axle and insert it into the muffler. Insert the **Over-Axle Pipe** hangers into the factory rubber insulators. Do not fully tighten the clamp yet.

Refer to Figure 6.

4. Slide a **2.5" Clamp** over the **Tail Pipe** and install it onto the **Over-Axle Pipe** (do not fully tighten), then insert the **Tail Pipe** hanger into the rear rubber insulator.

Refer to Figure 7.

5. Install and adjust the **Exhaust Tip** to suit. **Refer to Figure 8.**

6. Replace the spare-tire heat shield if it was removed.

MBRP



Figure 6



Figure 7



Figure 8

7. Align the edge of each band clamp with the edge of the joint it is connecting. Tighten all hardware and clamps, starting at the front and working rearward to secure the system. Check along the full length of the exhaust system to ensure there is adequate clearance for fuel lines, vent lines, brake lines, frame, bodywork, suspension, and any wiring, etc. If there is any interference detected, relocate, or adjust to provide adequate clearance. Ensure all clamp connections are secure and components are unable to rotate or slide. Band clamps require approximately 45 lb-ft (60 N-m) of torque. Verify clearances, system security and band clamp torque after 30-60 miles (50-100 km) of driving.



Congratulations! You are ready to begin experiencing the improved power, sound, and driving experience of your **MBRP** performance exhaust system. We know you will enjoy your purchase.