



**CAUTION: CAREFULLY READ INSTRUCTIONS BEFORE PROCEEDING**

## OVERVIEW

The WEGO IIIS is a single channel air/fuel ratio (AFR) metering system designed to be used with an existing data acquisition system. The system has a 0-5 volt analog AFR output. The compact size and wide supply voltage range also allow operation from small rechargeable batteries in a broad range of applications.

The system uses a low cost Bosch LSU 4.2 5-wire wide-band oxygen sensor. By utilizing miniature surface mount electronics technology, digital signal processing techniques, and a switching power supply for the sensor heater, the WEGO IIIS provides the same level of accuracy as lab systems costing thousands of dollars.

## REPLACEMENT SENSORS AND ACCESSORIES

The WEGO IIIS uses standard Bosch LSU 4.2 sensors used on a VW production application (Bosch P/N 0 258 007 057/058 or VW P/N 021 906 262B). The proprietary VW connector is replaced with a smaller Deutsch DT-04-6P. We offer replacement sensors with the Deutsch connector installed.

If you are testing multiple engines, we also offer additional 18 x 1.5 mm weld nuts for sensor mounting and 18 x 1.5mm hex socket plugs that screw into the weld nuts and allow removing sensors after tuning.

## INSTALLATION

1. Turn off the ignition switch and disconnect the battery ground cable before proceeding.
2. The Bosch LSU 4.2 sensor should be located on the header pipe about 6-8 inches from the head flange. Ideally the sensor tip should face down to avoid accumulation of condensation. When choosing a mounting location, allow several inches clearance for the sensor wire harness. The wire harness must exit straight out from the sensor. Do not loop the harness back onto the sensor body.
3. The 18 x 1.5 mm weld nut must be welded onto the exhaust pipe. After welding, run an 18 x 1.5 mm tap through the threads. Failure to clean the threads may result in sensor damage. Note that most automotive muffler shops are familiar with oxygen sensor weld nut installation on custom pipes. Do not install the sensors until after the free air calibration procedure described in the following section. Always use an anti-seize lubricant such as Permatex 133A on the sensor threads.
4. Install the WEGO IIIS unit. The unit is fully sealed, but should be mounted away from sources of engine or exhaust heat. The unit can be secured by means of two #8 screws through the mounting flanges. Use nylon tie wraps to secure the wire harness near the unit.
5. Connect the Bosch sensor to the 6 pin mating connectors on the WEGO IIIS wire harness. An extension cable (P/N 115004) is available.
6. Refer to Figure 1. Connect the thin black WEGO IIIS wire to the same point that the data acquisition system is grounded. Connect the heavy black wire to a good chassis ground location, preferably at the same location that the data acquisition system is grounded. Keep the ground connections as short as possible.
7. If your race vehicle uses any type of CD (capacitive discharge) ignition such as the MSD 6, 7, or 8 series, you must properly ground and filter the ignition unit. Unless your ignition unit is directly connected to the battery terminals, you must install a filter capacitor such as MSD P/N 8830. Visit [www.msdisignition.com](http://www.msdisignition.com), download the MSD 8 installation instructions, and refer to Figure 1 on the MSD instructions as a guide for installing the filter capacitor and grounding the ignition system. Do not ground your WEGO IIIS unit and data acquisition system to the same ground point used for the ignition system.
8. Connect the red WEGO IIIS wire to switched +12 volt power.
9. The WEGO IIIS parts bag includes a Packard Weather Pack connector that you can use to make a connection to your data acquisition system.
10. Reconnect the battery ground cable.

Figure 1 – Typical Vehicle Hookup for WEGO IIIS

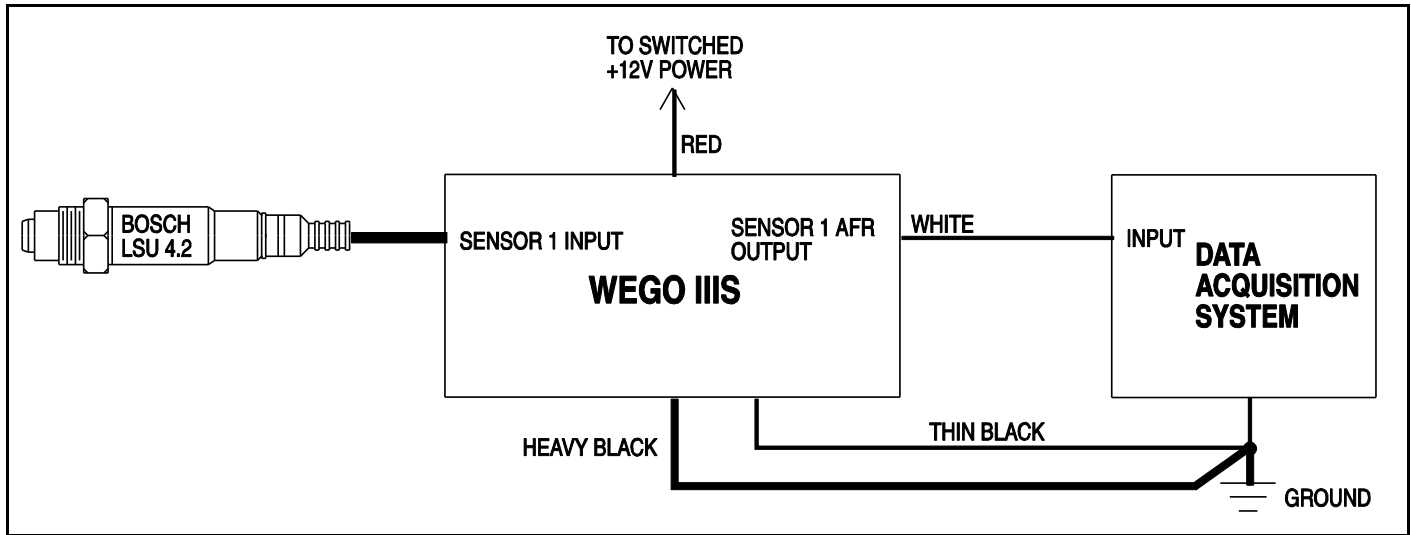

## OPERATION

For more information about wide-band oxygen sensors including the Bosch LSU 4.2, we suggest that you visit the Tech FAQ on our website at [www.daytona-sensors.com](http://www.daytona-sensors.com).

The WEGO IIIS has a red status LEDs. When power is turned on, the LED blinks at a slow rate until the sensor has reached normal operating temperature.

After installation, the WEGO IIIS requires free air calibration. This should be done with the sensor dangling in free air. The environment must be free of hydrocarbon vapors. We suggest that you perform the free air calibration outdoors. Turn the free air calibration trimpot on the WEGO IIIS full counterclockwise. Turn on power and wait for 60 seconds so the system can fully stabilize. Then slowly turn the free air calibration trimpot clockwise until the LED starts flashing at a rapid rate. Try to set the trimpot at the point where its LED just starts to flash.

The free air calibration procedure should be performed at reasonable intervals (every 250-500 hours if using unleaded gas or every 2-5 hours if using leaded racing gas) or whenever a sensor is replaced. If you cannot get the LED to flash when the trimpot is turned full clockwise, you either have a damaged sensor or very high hydrocarbon levels in your environment.

The WEGO IIIS includes internal diagnostics for abnormal battery voltage (less than 11 volts or greater than 16.5 volts), sensor open circuit, and sensor short

circuit conditions. A fault condition causes the status LED to blink at the slow rate.

## EXHAUST CONSIDERATIONS

The WEGO IIIS system may give inaccurate results in certain situations:

**Excessive exhaust back pressure.** Wide-band sensors are affected by back pressure. Excessive back pressure causes exaggerated AFR indications under rich and lean conditions, but has little effect at 14.7 AFR (stoichiometric). Race vehicle exhaust systems are free flowing and problems with exhaust back pressure are not likely.

**Exhaust reversion.** Reversion is the term for a negative pressure wave that can suck ambient air back into the exhaust and cause an erroneous lean AFR indication. Open "drag pipes" usually suffer from reversion effects and may not be suitable for use with the WEGO IIIS except at or near wide open throttle. Reversion effects will be most noticeable at idle, part throttle low RPM, and decel.

**Excessive scavenging.** Tuned exhausts in combination with a high overlap camshaft profile can pull unburned air and fuel mixture through the cylinder

**CAUTION: Racing gasoline containing lead will quickly degrade the sensor. Under these conditions, expected sensor life is less than 10 hours. There is no warranty on sensors.**

into the exhaust and cause an erroneous rich AFR indication. The same effect can occur with high boost turbo/supercharger applications.

**Misfiring.** If the AFR is so rich that the engine misfires, high levels of oxygen will remain in the exhaust gas and result in an erroneous lean indication.

## **GASOLINE ENGINE TUNING GUIDELINES**

Higher AFR values correspond to a leaner (less fuel) condition. The practical operating range for most engines using gasoline fuel is from approximately 11.5 to 14.7 AFR. Combustion of a stoichiometric mixture (exactly enough air to burn all the fuel) results in 14.7 AFR indication. Automotive engines with catalytic converters operate near 14.7 AFR during cruise and idle. Race engines usually require a richer mixture to limit cylinder head temperature and prevent detonation. The table below lists reasonable AFR values for race engines without emission controls.

<b>Operating Mode</b>	<b>Recommended AFR</b>
Cold Start (first 30 sec)	11.5-12.5 AFR 0.78-0.85 Lambda
Idle	12.8-13.5 AFR 0.87-0.92 Lambda
Part Throttle Cruise	13.0-14.0 AFR 0.88-0.95 Lambda
Wide Open Throttle (normally aspirated)	12.5-12.8 AFR 0.85-0.87 Lambda  Values down to 11.5 AFR or 0.78 Lambda may be used to reduce detonation)
Wide Open Throttle (turbo/supercharged)	10.8-11.8 AFR 0.73-0.80 Lambda

## **DATA ACQUISITION**

The 0-5 volt analog output (white wire) from the WEGO IIIS is compatible with most data acquisition systems that have an available analog input. **We do not offer any technical assistance on interfacing to your data acquisition system. You must contact the vendor for support.**

WEGO units are useful in a wide range of engine tuning and testing applications. After free air calibration, accuracy is  $\pm 0.1$  AFR or  $\pm 0.007$  Lambda.

All WEGO units have the same scaling for the 0-5 volt analog output on the white wire:

### **Gasoline:**

$$\text{AFR} = 2 \times (\text{Vout} + 5) \quad \text{or}$$

$$\text{Vout} = (0.5 \times \text{AFR}) - 5$$

### **Lambda:**

$$\text{Lambda} = .1361 \times (\text{Vout} + 5) \quad \text{or}$$

$$\text{Vout} = (7.345 \times \text{Lambda}) - 5$$

Additional scale factors are listed on our Tech FAQ at [www.daytona-sensors.com](http://www.daytona-sensors.com).

Note that when power is first turned on and the sensor is not yet at its normal operating temperature, the analog output is held at less than 0.20 volts. During free air calibration and while the WEGO IIIS status LED is rapidly blinking, the analog output will be near 5.0 volts.

Figure 2 – Typical Dyno Hookup for WEGO IIIS

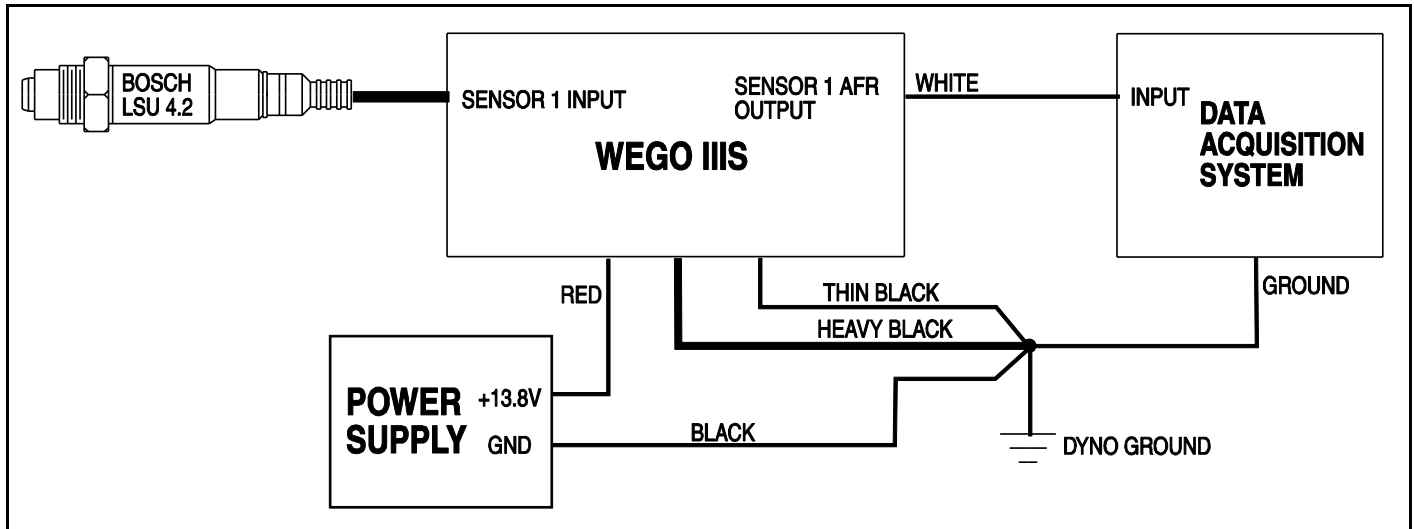

## DYNO WIRING HOOKUP

Refer to Figure 2. The power supply must be located in close proximity to the WEGO unit. We recommend mounting the WEGO unit on a panel next to the dyno data acquisition system and then running extension cables out to the sensors in the dyno room. **Keep all power and ground connections as short as possible. Follow the exact layout shown in Figure 2. Do not add additional terminal blocks or connectors to power or ground connections.**

## DYNO GROUNDING

Improper grounding will cause serious problems. The dyno frame or chassis must be connected to building electrical ground in accordance with National Electrical Code (NEC) requirements.

Vehicles operated on a chassis dyno will generate considerable electrostatic charge. The vehicle must be grounded to the dyno frame while in operation. You can use a length of 16 AWG wire with one end secured to the dyno frame and the other end equipped with a heavy duty alligator clip that is attached to the vehicle frame or other vehicle ground point. Failure to ground the vehicle will lead to electrostatic discharge (ESD) across the WEGO sensor damaging the sensor and WEGO unit.

## WEGO POWER REQUIREMENTS

WEGO systems are intended for nominal 12 volt automotive applications. Nominal 12 volt automotive electrical systems on alternator equipped vehicles typically operate at 13.8-14.4 volts while the engine is running. The WEGO can operate from 9.0 to 18.0 volts.

WEGO units also feature low power consumption (about 1 amp). For small engine applications, you can power the WEGO for over one hour from a 12 volt gel cell type rechargeable battery, such as the type used for backup power in alarm systems.

Vehicles with nominal 12 volt total loss electrical systems (no alternator) can momentarily drop below the 9.0 volt minimum level when heavy loads, such as fans or nitrous solenoids engage. This will cause the WEGO to reset and result in a loss of data for 10-15 seconds.

Vehicles with nominal 16 volt electrical systems equipped with race type alternators may reach 18.6 volts while the engine is running. The WEGO will shut off if the voltage exceeds 18.0 volts. Call our tech support before attempting to install any WEGO system on a nominal 16 volt electrical system with an alternator.

# TROUBLESHOOTING FLOWCHART

error, degraded sensor, or bad power connections is later identified.

Follow the troubleshooting flowchart shown below. Experience has shown that most units returned for warranty are OK and another problem, such as user

## Troubleshooting Flowchart

