

**FORD SUPER DUTY REAR WITHOUT FLARES MUD GUARD
INSTALLATION INSTRUCTIONS**

Install Paint Protection Film before mud guards (see other side). Please read instructions thoroughly before installation.

Tools Required

- 1/8" drill bit / Drill
- Short Phillips screwdriver or drill attachment

Package Contents

- Driver & passenger side rear mud guard
- #10 SEM screw (qty. 8)
- U-clip (qty. 8)
- Paint Protection Film (1 set)
- Instruction sheet

NOTE: It may be necessary to remove the wheels depending on the tools being used for installation.

Determine which mudguard you have by locating the part number molded in the mounting flange (5768 LH 5768 RH).

1. Clean and degrease the mud guard location area on the fender before installation.
2. Install U-clips at location A and B over the existing hole in the fender (Figure 3).
3. Attach mud guard to rear fender with #10 SEM screw at location A and B, check fit before tightening.
4. Install a #10 SEM screw through location C and into a u-clip on the back side of the fender. (Figure 2).
5. **OPTIONAL FASTENER** Using the mudguard as a template drill an 1/8" hole at location D through the fender liner.
6. Install a #10 SEM screw through location D and into a U-clip on the backside of the liner (Figure 2).

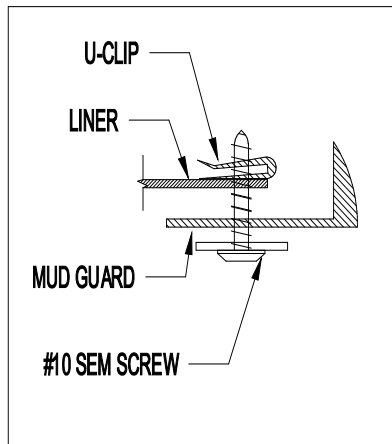

Figure 2

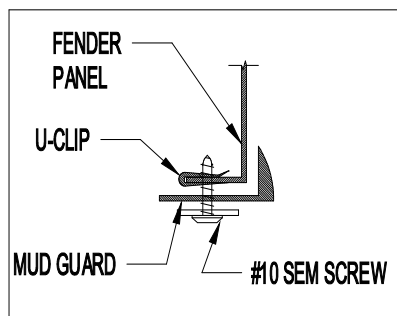

Figure 3

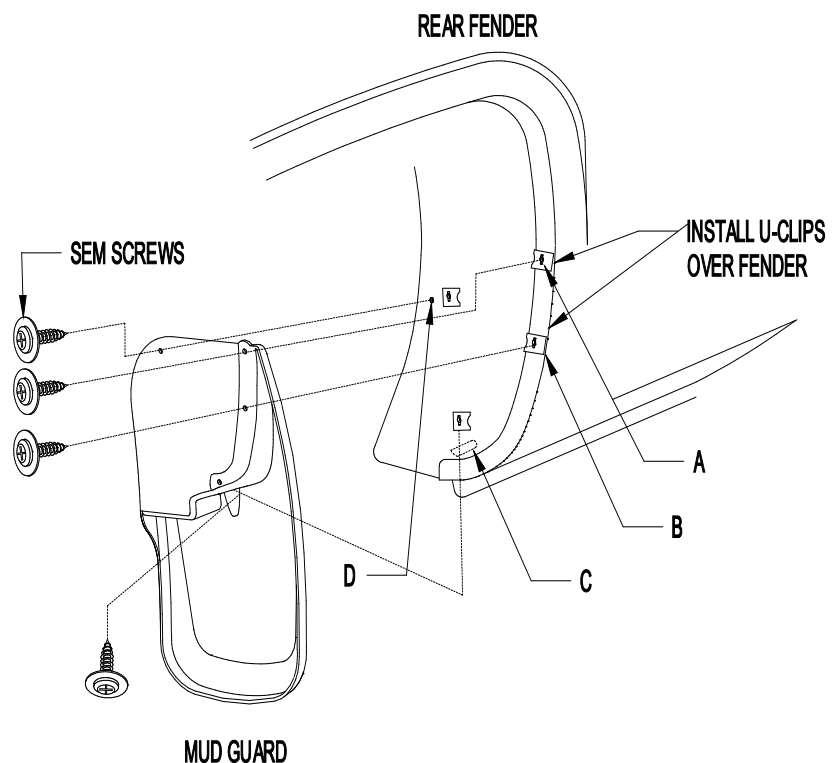

Figure 1

View the Husky Liners® Lifetime Warranty at www.huskyliners.com/lifetime-warranty.
Patent and Trademark can be found at www.hl-ip.com

**PAINT PROTECTION FILM
INSTALLATION INSTRUCTIONS**

NOTE: *The Paint Protection Film is a precut template of film used to protect the mud guard mounting surfaces of your fenders against wear. The templates (left and right side) can be removed from the backing liner by folding the liner at the center cut of the template, separating the film sides and peeling the film templates from the backing liner.*

1. Position mud guard on fender to indicate placement location of paint protection film.
2. Clean the placement area of fender with a clean cotton cloth and a petroleum distillate based cleaner such as DuPonts Prep-Sol Brand Solvent Cleaner or 3M Brand Adhesive Cleaner and dry.
3. Mix a wetting solution of 1 pint of water with 4 drops of liquid dishwashing detergent.
4. Mark correct position of film by placing mud guard against fender. **Make sure film extends beyond edge of mud guard contour a minimum of an 1/8"**.
5. Remove protection film from liner and flood adhesive side of film with wetting solution (use a spray bottle or sponge).
6. Thoroughly wet film placement location of fender with wetting solution.
7. Position the adhesive side of film on fender and flood with wetting solution.
8. Check location of film with mud guard and reposition as necessary.
9. Using a sponge, squeegee any air bubbles and wrinkles from film.
10. Allow film to dry before installing mud guard.

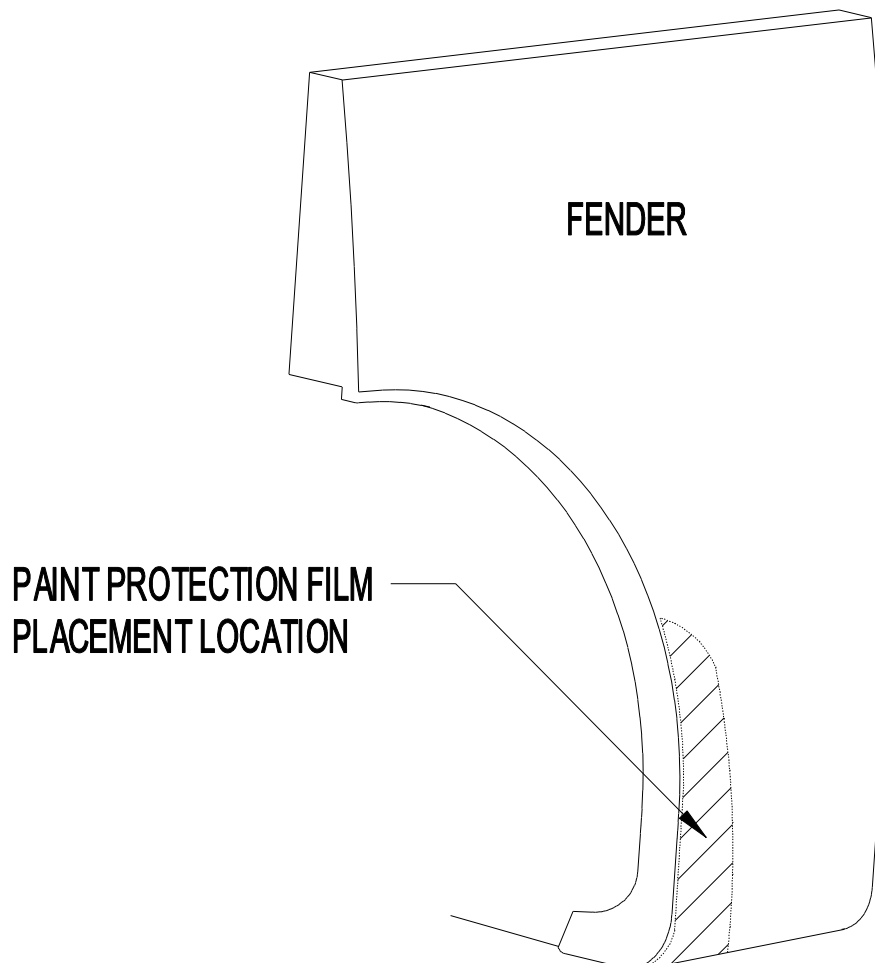



PART NO. **5768**