



7103HKR 1968-74 AMC Javelin AMX & 1974 AMC Matador 290-401 CID

Thank you for making HOOKER HEADERS your choice in a high-performance exhaust system. Extensive dyno/track testing has enabled HOOKER to offer the most advanced design in headers for your application. Due to the restricted room available in the engine compartment, your headers may be close to some body and chassis components. This condition is normal. The installation, while not complex, will take a certain amount of time. However, the additional horsepower and improved performance will more than justify your efforts. Proper installation and maintenance will ensure long life and maximum performance from your HOOKER exhaust system.

WARNING! Breaking in an engine with ceramic-coated headers WILL result in damage to the coating and will VOID all warranties. Ceramic-coated headers require several heat cycles to fully cure before they will withstand extreme heat. Hooker® recommends using a cast iron exhaust manifold or old headers to break in new engines to avoid coating damage. Please call tech service at 270-781-9741 or 1-866-GOHOLLEY for additional information regarding ceramic-coated exhaust products.

BEFORE STARTING

Your vehicle must be raised a minimum of 36 inches. A floor hoist is ideal. If no hoist is available we strongly urge the use of axle stands as a safety measure. **CAUTION!** Your car should not be supported on a bumper jack.

INSTALLATION PROCEDURE – PLEASE READ CAREFULLY!

LEFT SIDE

1. Disconnect the battery cable to prevent damage to the electrical system.
2. Unbolt the headpipe from the exhaust manifold and push aside.
3. Remove the clutch linkage, dipstick tube, spark plugs, and stock exhaust manifold.
4. Starting from below, work the header up through the chassis into position.
5. Place the gasket into position and start all bolts (most restricted first).

NOTE: Vehicles equipped with smog injection tube: Remove tubes from stock exhaust manifold and install on header (**Figure B**).

6. Tighten all bolts evenly.
7. Replace the clutch linkage, dipstick tube, and spark plugs.

NOTE: 1973 – 76 Javelins and 1975 Matadors: Modify the motor mount to clear the header by trimming the corner (approx. ½" x 45°). See **Figure A**.

RIGHT SIDE

1. Remove the spark plugs, starter, and exhaust manifold. Unbolt the transmission filler tube from the back of the head (if automatic).
2. Remove the bolt from the motor mount and raise the engine about one inch. Use a board between the pan and jack.
3. Starting from below, work the header up through the chassis into position and start the front bolt. Lower the engine and replace the motor mount bolt.
4. With the header loose, reinstall the starter.
5. Remove the front bolt, place the gasket into position, and start all bolts (most restricted first).

NOTE: Vehicles equipped with smog injection tube: Remove tubes from stock exhaust manifold and install on header (**Figure B**).

6. Tighten all bolts evenly.

NOTE: If equipped with automatic transmission, check the trans cooler lines for adequate header clearance. Reroute, as required. We recommend fabricating an extension for the filler tube bracket before reinstalling the head.

7. To retain heat to the carburetor, attach the heat stove to the header tube with hose clamps (all purchased) and connect to the stock flex hose (from air cleaner) with a third hose clamp. See **Figure C**.
8. To connect collectors to the headpipes, purchase Hooker reducer kit 11035HKR.

NOTE: A dual exhaust system can be fabricated using either the HOOKER competition turbo mufflers (21105HKR or 21106HKR), or the HOOKER competition turbo (21005HKR or 21006HKR).

9. Connect the battery, start the engine, and check for leaks. Be sure that all brake lines, fuel lines, and electrical wires have sufficient clearance.
10. When finished, give your car a test drive checking for any new noises. After several days of driving, retighten all bolts.

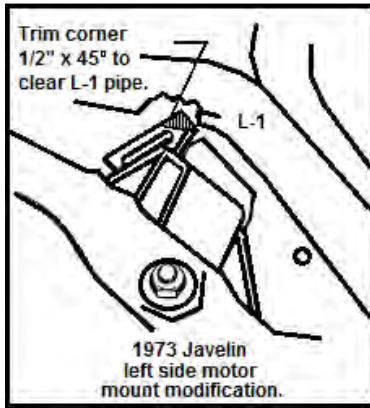

Figure A

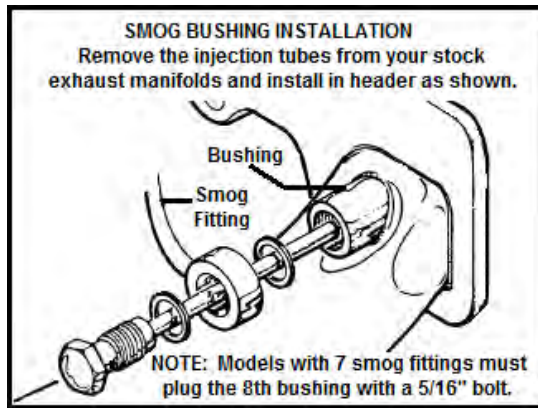

Figure B

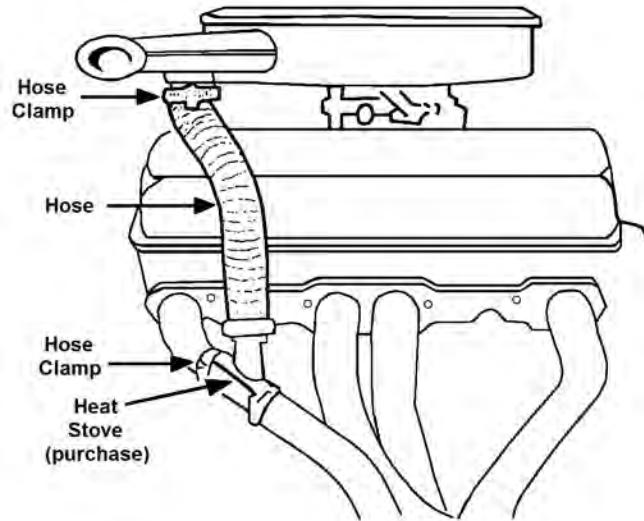

Figure C

LIMITATION OF LIABILITY – DISCLAIMER

The regulation of emissions production, noise levels, and safety standards is undertaken by the federal government, each of the fifty state legislatures, and by many local municipalities, towns, and counties.

HOKKER Industries makes no warranties of merchantability, of fitness for particular purpose, or that its products are approved for general use, or that its products comply with laws, regulations, or ordinances in the states where they may be sold to the ultimate purchaser, the consumer.

Unless expressly stated to the contrary in the catalog, instruction sheet, or price list, the entire risk as to the conformity of any company product in any such state and as to repair should the product prove to be defective or nonconforming, is on the retail purchaser, the buyer, the ultimate consumer, of such product and it is not upon the seller, distributor, or manufacturer.

In this connection, the retail purchaser, the buyer, the ultimate consumer assumes the burden of the entire cost of any and all necessary service, alterations, or repair.

The foregoing statement limits the liability of the manufacturer.

California vehicle code sections 27156 and 38391 prohibit the advertising, offering for sale, or installation of any device, which modifies a vehicle's emission control system unless exempted. Unless otherwise noted, HOKKER HEADERS have not received an exemption from these code sections and are not legal for sale or use in California on vehicles originally equipped with catalytic converters. It is illegal, except for racing vehicles, which may never be driven upon a highway, to remove or otherwise render inoperative any emission control device on regulated motor vehicles. Check catalog listings to ensure proper application. In the other 49 states, unless otherwise noted, HOKKER HEADERS are not legal for pollution controlled motor vehicles, except for racing vehicles, which may never be used upon a highway and are not intended or applicable for highway use.

HOKKER TECHNICAL SUPPORT
Toll-Free Phone: 1-866-GOHOLLEY
Phone: 1-270-781-9741
Fax: 1-270-781-9772

For online help, please refer to the Tech Service section of our website: www.holley.com

7103HKR

Revised: 8-18-11