

PARTS LIST

**OUTER BUMPER KIT
(PAGE 4 & 5)**

2 - RE-INFORCING PLATES (YJ)
2 - RE-INFORCING PLATES (TJ)
2 - INNER FRAME NUTS (TJ)
4 - 7/16 X 1 3/4 BOLTS
2 - 7/16 X 1 1/4 BOLTS
10 - 1/2 SAE FLATWASHERS
6 - 7/16 LOCKWASHERS
4 - 7/16 NUTS

**LOWER SUPPORT BRACKET KIT
(PAGE 7, FIGURE J)**

2 - LOWER SUPPORT BRACKETS
4 - 7/16 X 1 1/4 BOLTS
6 - 1/2 SAE FLATWASHERS
4 - 7/16 LOCKWASHERS
2 - 7 1/6 NUTS

**MIDDLE STOP LIGHT KIT
(PAGE 7, FIGURE K)**

1 - RE-LOCATION BRACKET
2 - 1/4 X 3/4 BOLTS
2 - 1/4 X 1 BOLTS
8 - 1/4 FLATWASHERS
4 - 1/4 NYLON LOCKNUTS

**LATCH ASSEMBLY KIT
(PAGE 3, FIGURE B)**

1 - ASSEMBLED LATCH & PULL PIN
4 - 1/4 X 3/4 BOLTS
4 - 1/4 LOCKWASHERS
4 - 1/4 FLATWASHERS

**INNER BUMPER KIT
(PAGE 5, FIGURE G)**

2 - 7/16 NUT PLATES (RT & LT)
4 - 7/16 X 1 1/4 BOLTS
4 - 1/2 SAE FLATWASHERS
4 - 7/16 LOCKWASHERS

**TAILGATE BUMPER KIT
(PAGE 6, FIGURE H)**

1 - TAILGATE BRACKET
1 - RUBBER BUMPER (2" DIA.)
1 - 3/8 X 2 TAP BOLT (ALL THREAD)
1 - 3/8 USS FLATWASHER
1 - 3/8 FENDER WASHER (2" DIA.)
3 - 3/8 JAM NUTS
2 - 3/8 SAE FLATWASHERS

**TIRE MOUNT KIT
(PAGE 8)**

1 - TIRE MOUNT BRACKET
1 - 1/2 X 3 BOLT
2 - 1/2 SAE FLATWASHERS
1 - 1/2 NYLON LOCKNUT

FACTORY INSTALLED PARTS

1 - GREASE FITTING (PLASTIC BAG)
1 - 1/2 X 3 BOLT, FLATWASHERS AND LOCKNUT
4 - 1/4 X 3/4 BOLTS, LOCKWASHERS
FLATWASHERS (LATCH MOUNTING)

ALL SWING ARM PIVOT HARDWARE
1 - 1 1/4 LOCK NUT
1 - 1/4 STEEL SPACER (SILVER IN COLOR)
1 - 2" NYLON FLATWASHER (BLACK)
1 - 2" THRUST WASHER (GOLD IN COLOR)

Part#71000
Installation Instructions

1. Remove factory rear bumper, spare tire carrier and all rubber stops on tailgate. If equipped with a center stop light, remove that as well. Cut the center stop light wiring in a position that allows for easy extension of wires and re-connection later.
2. 97-06 Wranglers require drilling 4-1/2" dia holes through rear crossmember, as shown on page 4, figure C. 87-95 Wranglers require no drilling in crossmember.
3. Install lower support brackets to rear of frame, as shown on page 7, figure J.
4. Install rear bumper to lower support brackets, page 7, figure J, leave bolts loose. This will support the bumper while installing the other eight bolts.
5. Use the re-inforcing plates on the four outboard bolts, page 5, fig. E & F, located behind the crossmember. And also the 7/16 nut plates(right and left) on the inboard bolts, as shown on page 5, fig. G.
6. Align bumper and tighten all mounting hardware.
7. Install tailgate mounting bracket to tailgate, re-using factory bolts, center bracket and tighten hardware. Refer to page 6, figure H.
8. Install rubber bumper to tailgate mounting bracket, page 6, fig. H.
9. Install top swing-away assembly to bumper, page 3. Note! Brass thrust washer(Gold) goes on the bottom. Before installing top section, grease pivot shaft. Install grease fitting and re-grease before installing hold down nut.
10. Tighten 1 1/4" thin locknut until there is no longer any up and down movement in the swing arm.
11. Install latch assembly to swing arm , as shown on page 3, figure B.
12. If applicable, install optional Hi-lift bracket(part#71099) to swing-away assembly, refer to page 6, fig. I.
13. Install spare tire assembly, refer to page 8.
14. After installing spare tire and accessories, adjust rubber bump stop against the plate on rear of tire mount receptacle. Adjust it so you have approx. 3/8" space at latch assembly. Refer to page 3, figure B.
15. Adjust the "U" bolt nuts on the latch assembly so that the handle snaps closed.
16. Modify and install brake light assembly to swing-away bracket, as shown on page 7, fig. K.
17. The Wilderness rear bumper and receiver is rated at Class II-3500# GTW and 350# tongue weight, use the brackets welded to the rear portion of the bumper as safety chain mounting points.
18. It is recommended that you use the receiver hitch as a vehicle retrieval mounting point. Use a Warn(Part# 29312) or Superwinch(Part# 2546) receiver shackle bracket with clevis pin. Not doing so could cause the shackle mount point to bend under a heavy angle pull.
19. Swing Away Regular Maintenance: 1. Spray latch assembly with lubricant on a regular basis. 2. Grease swing-arm at least every 30 days. If swing-arm starts to get difficult to open, remove, clean and re-grease, using a marine quality water proof grease. 3. Nicks and scratches should be touched up with a satin black paint to prevent rusting.
20. Page 3, figure A, shows the optional accessory that is available for your swing-away bumper system #71000

FIGURE A

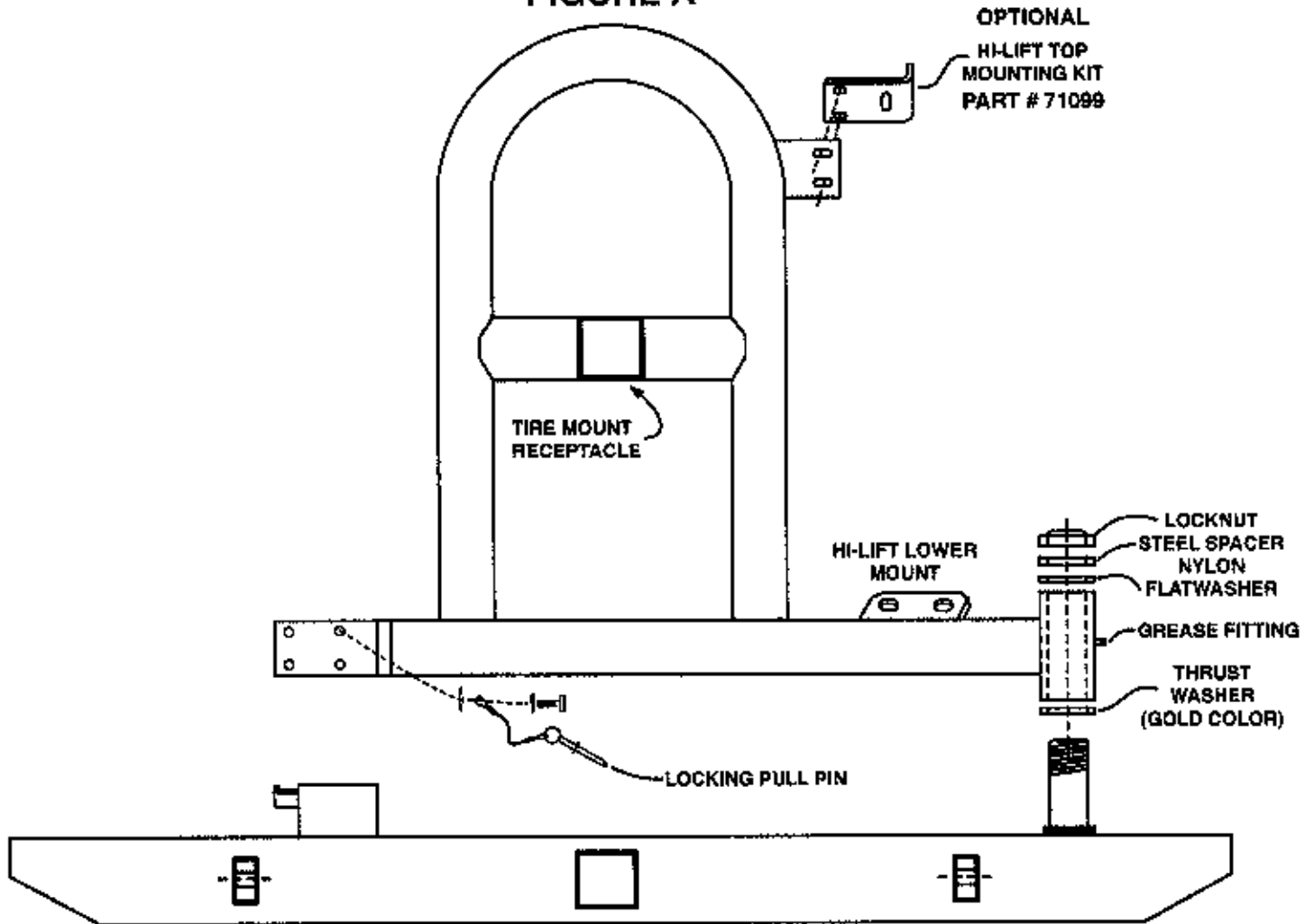

FIGURE B LATCH ASSEMBLY WITH PULL PIN

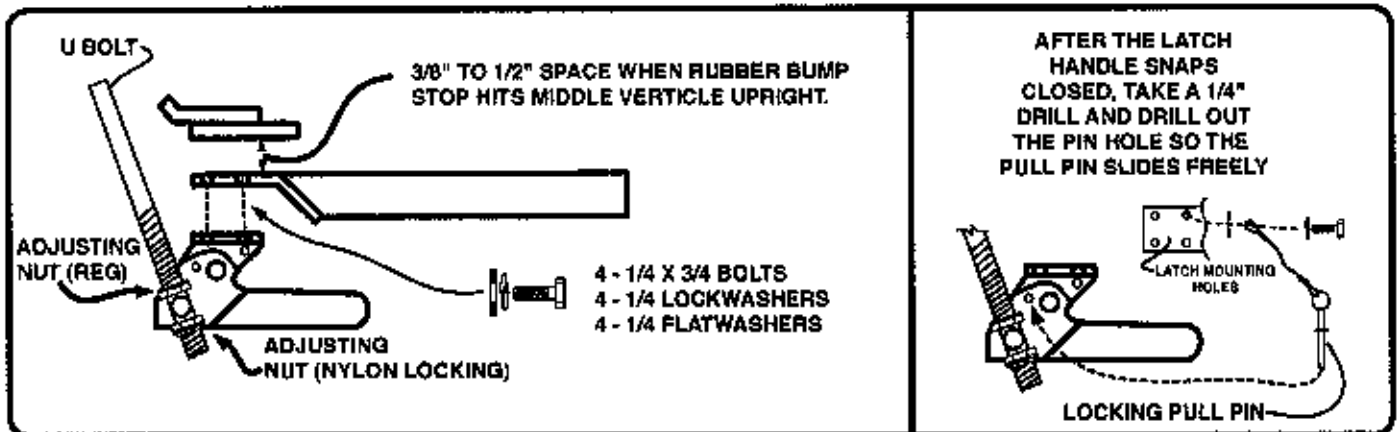

FIGURE C (DRILLING DIAGRAM FOR 97 - 06 JEEP WRANGLER MODELS ONLY)

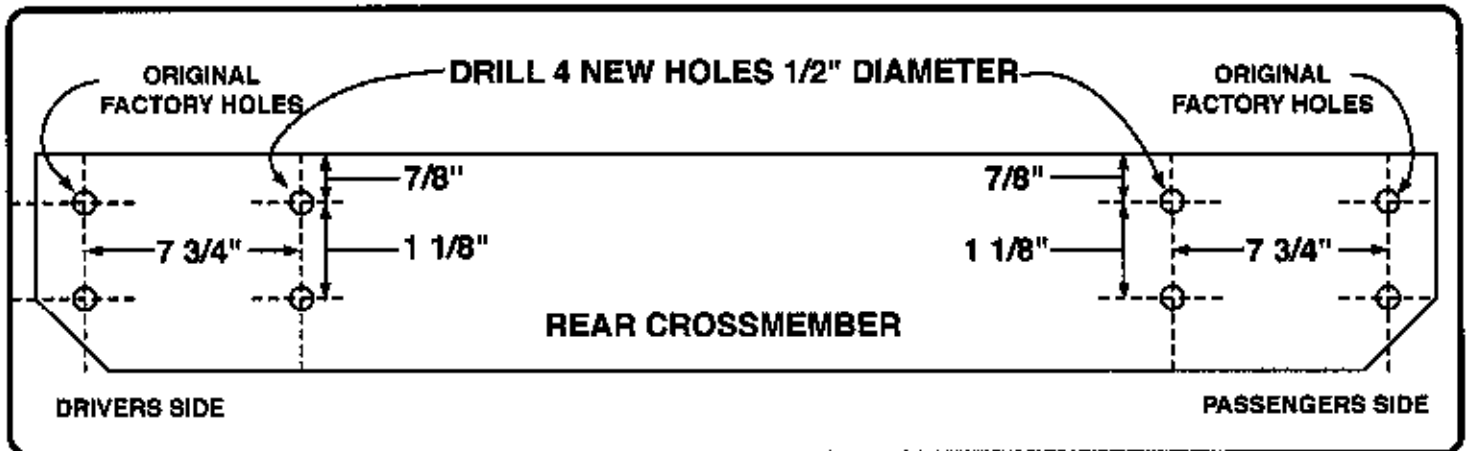

FIGURE D

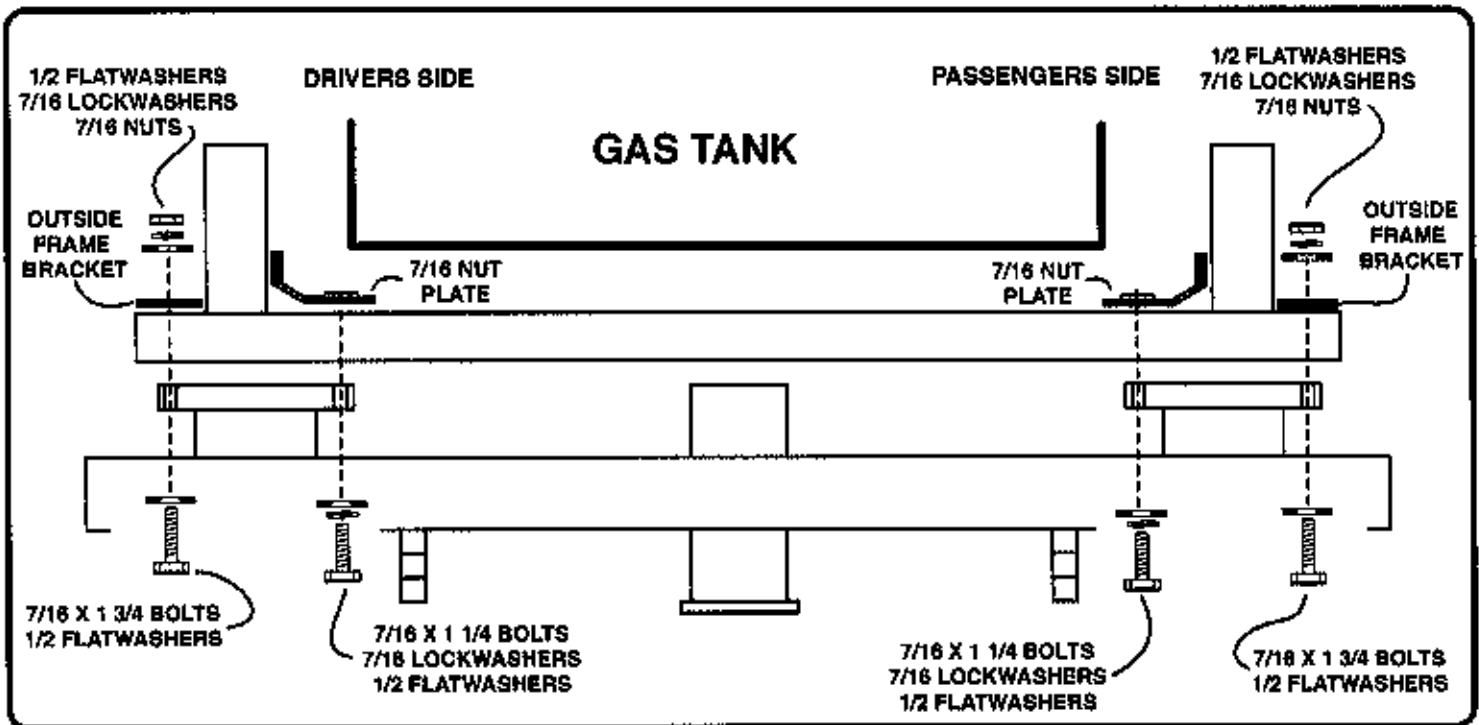

FIGURE E (TJ JEEP 97 - 06)

FIGURE F (YJ JEEP 87 - 95)

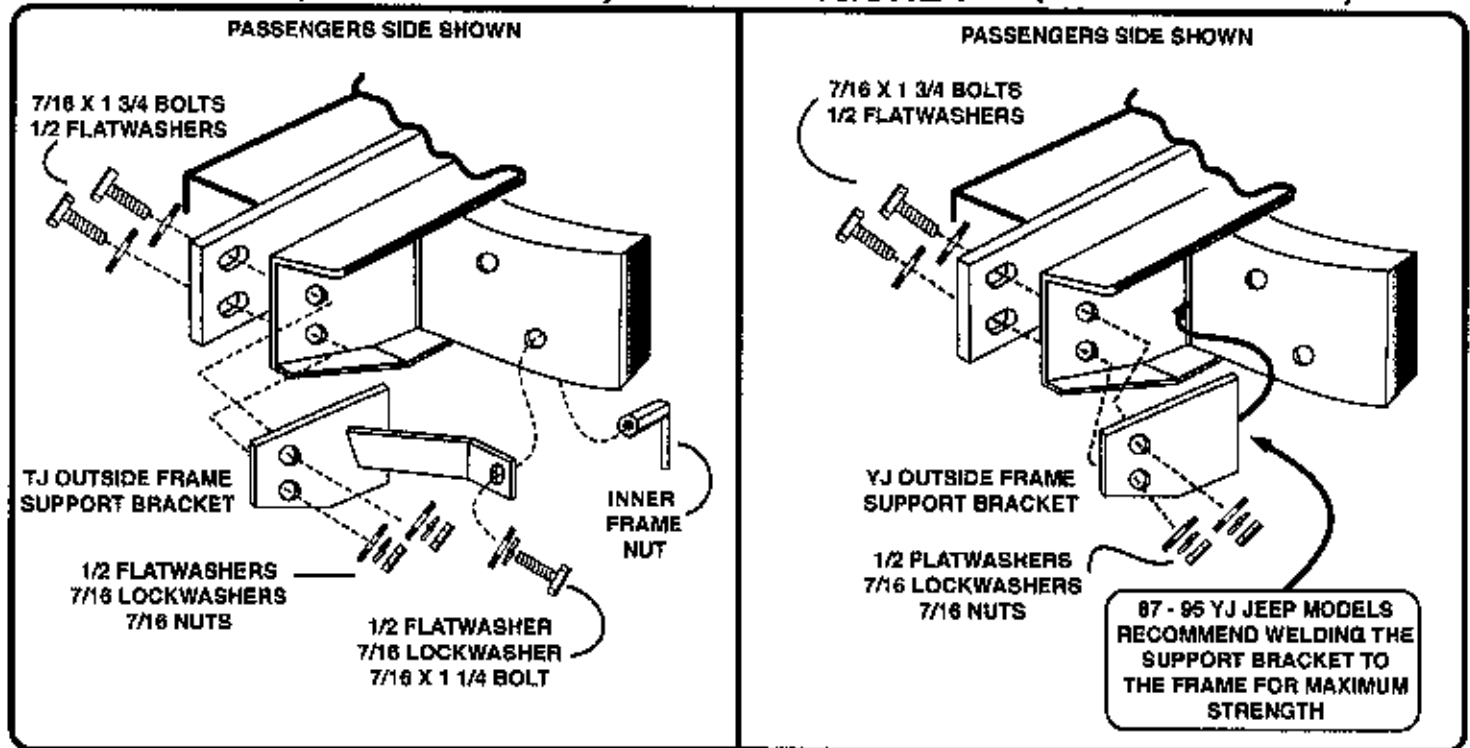
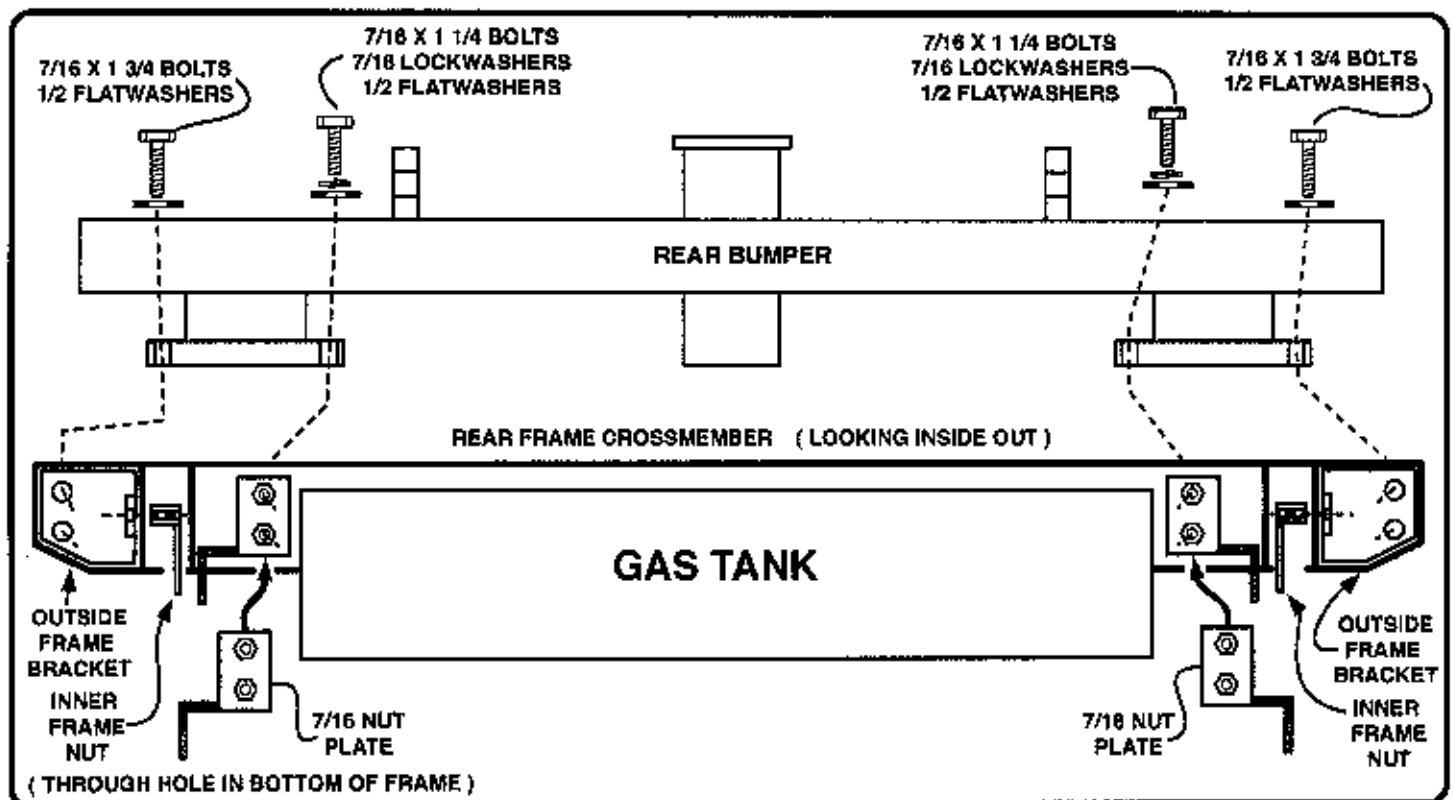
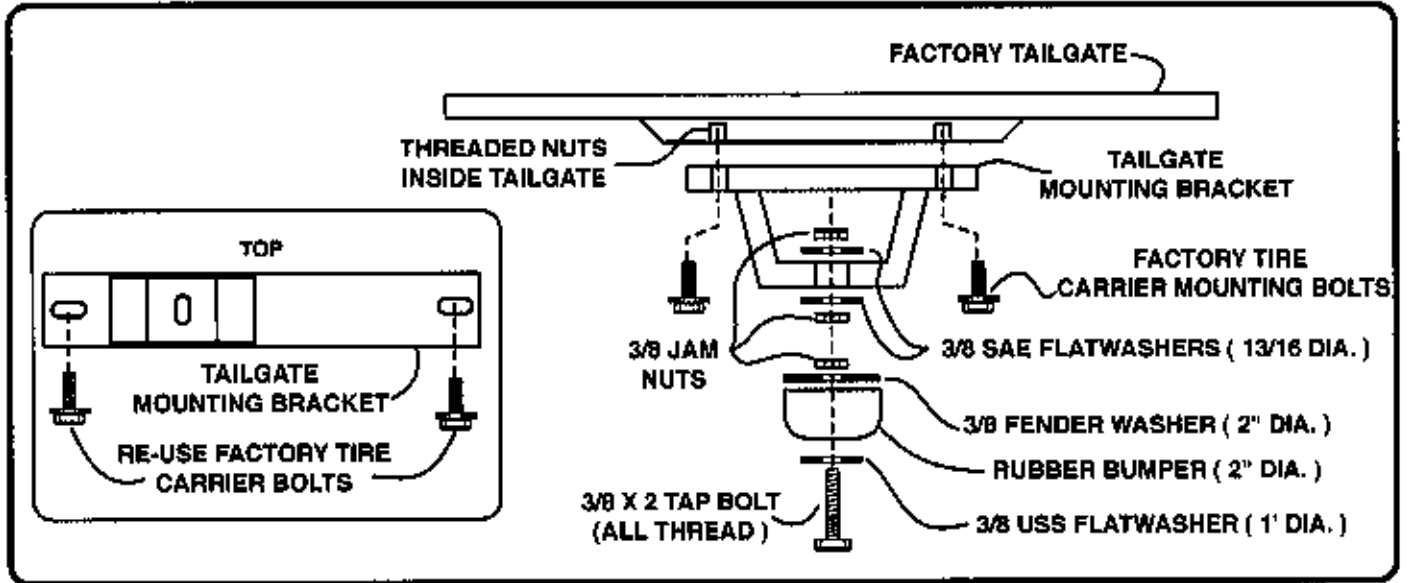

FIGURE G



TAILGATE BRACKET ASSEMBLY AND HI-LIFT MOUNTING

FIGURE H



THIS DRAWING SHOWS THE INSTALLATION OF THE OPTIONAL HI-LIFT MOUNTING BRACKET, PART # 71099, WHEN INSTALLED ON THE ATS SERIES BUMPER PART #71000.

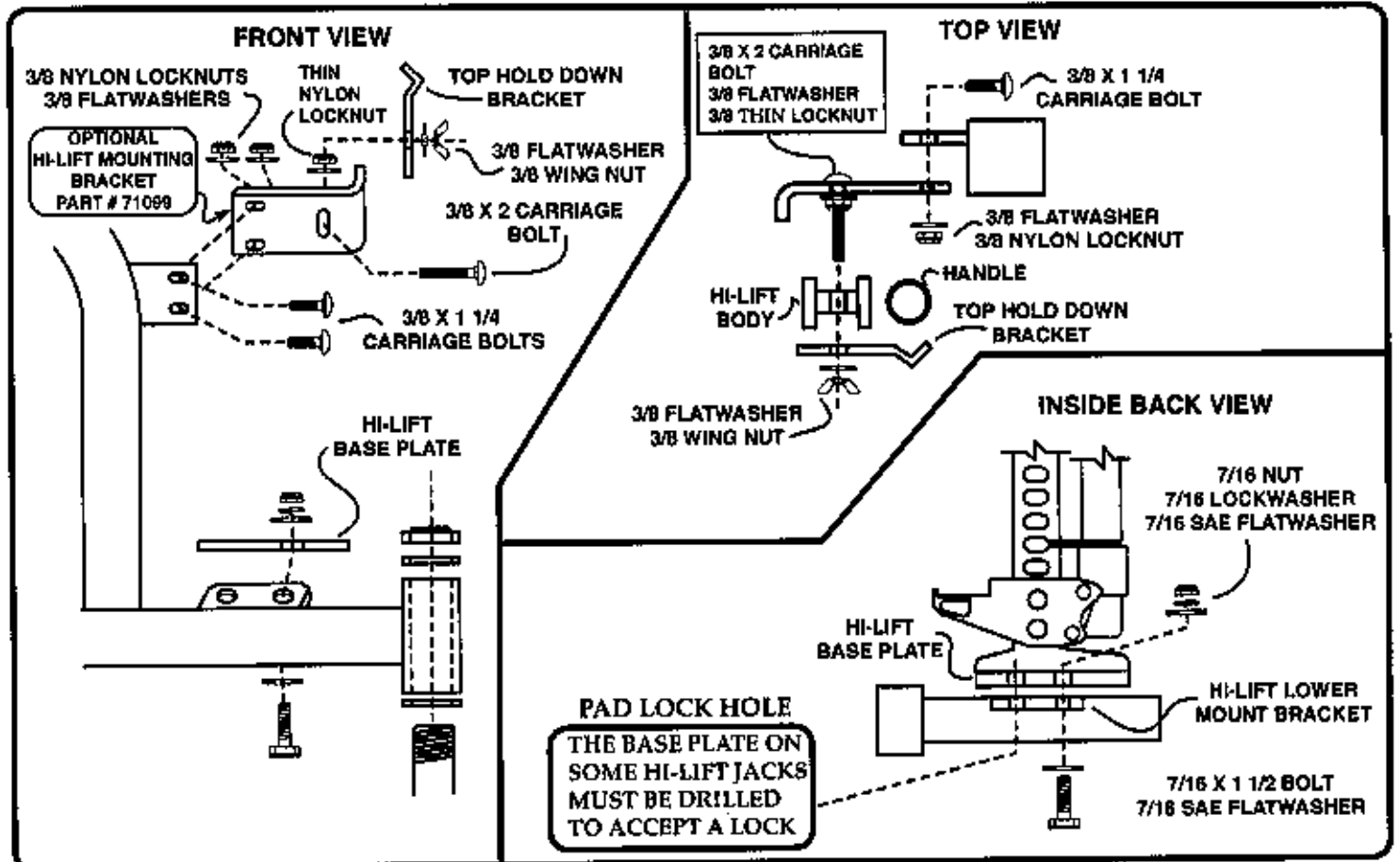

INSTALLATION INSTRUCTIONS

FIGURE J (REAR BUMPER LOWER SUPPORT BRACKET)

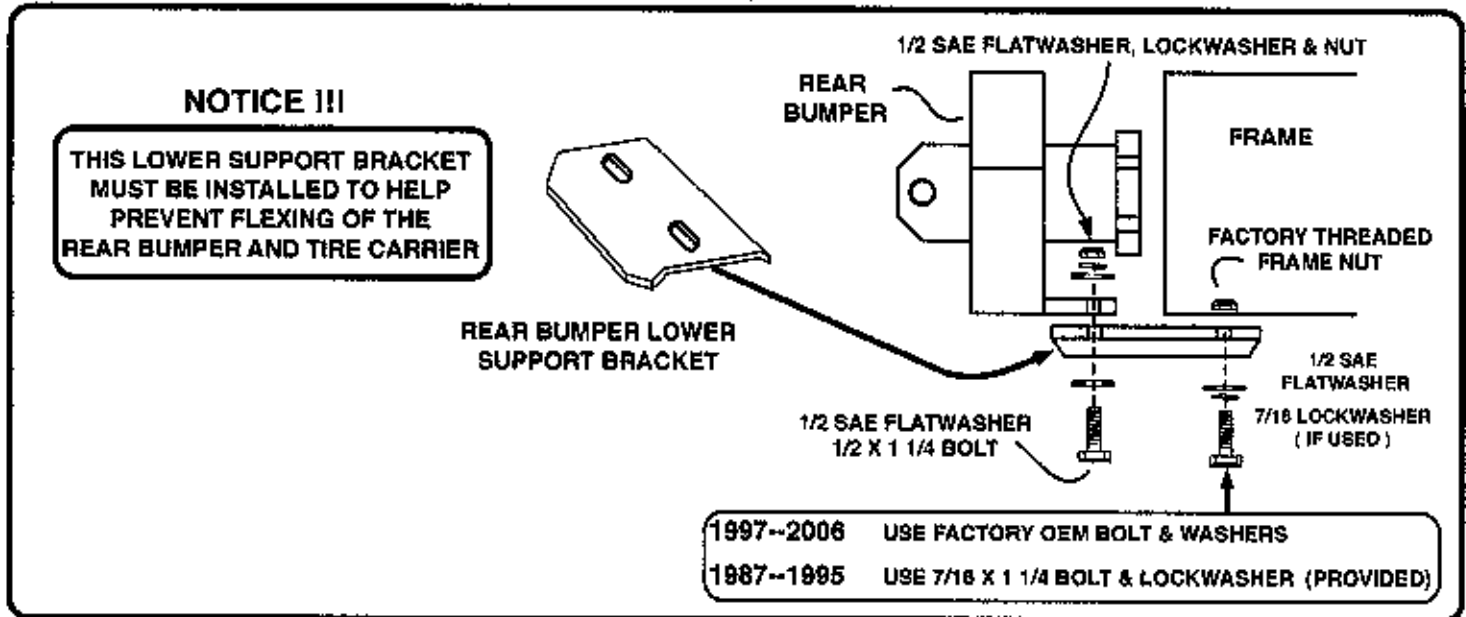
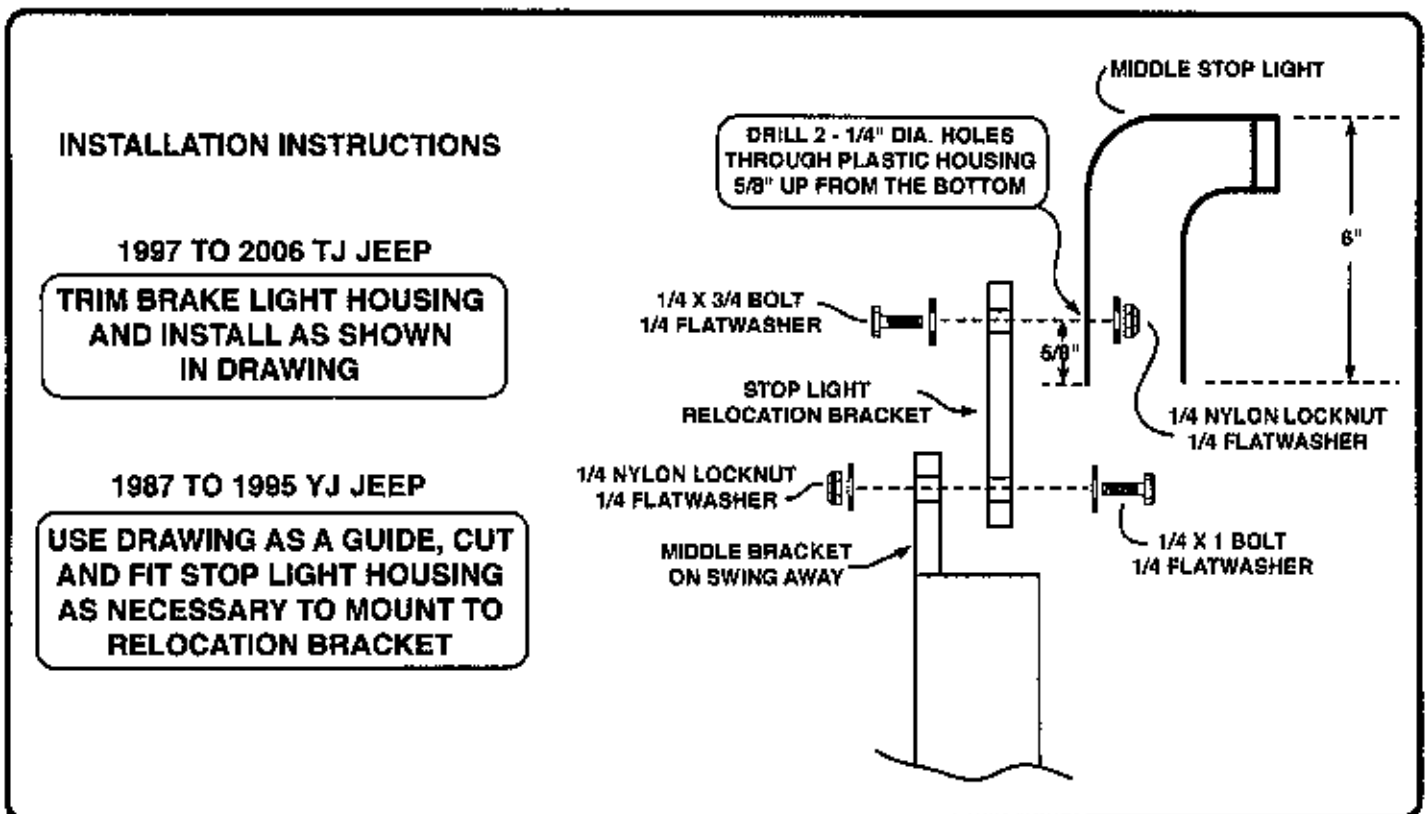
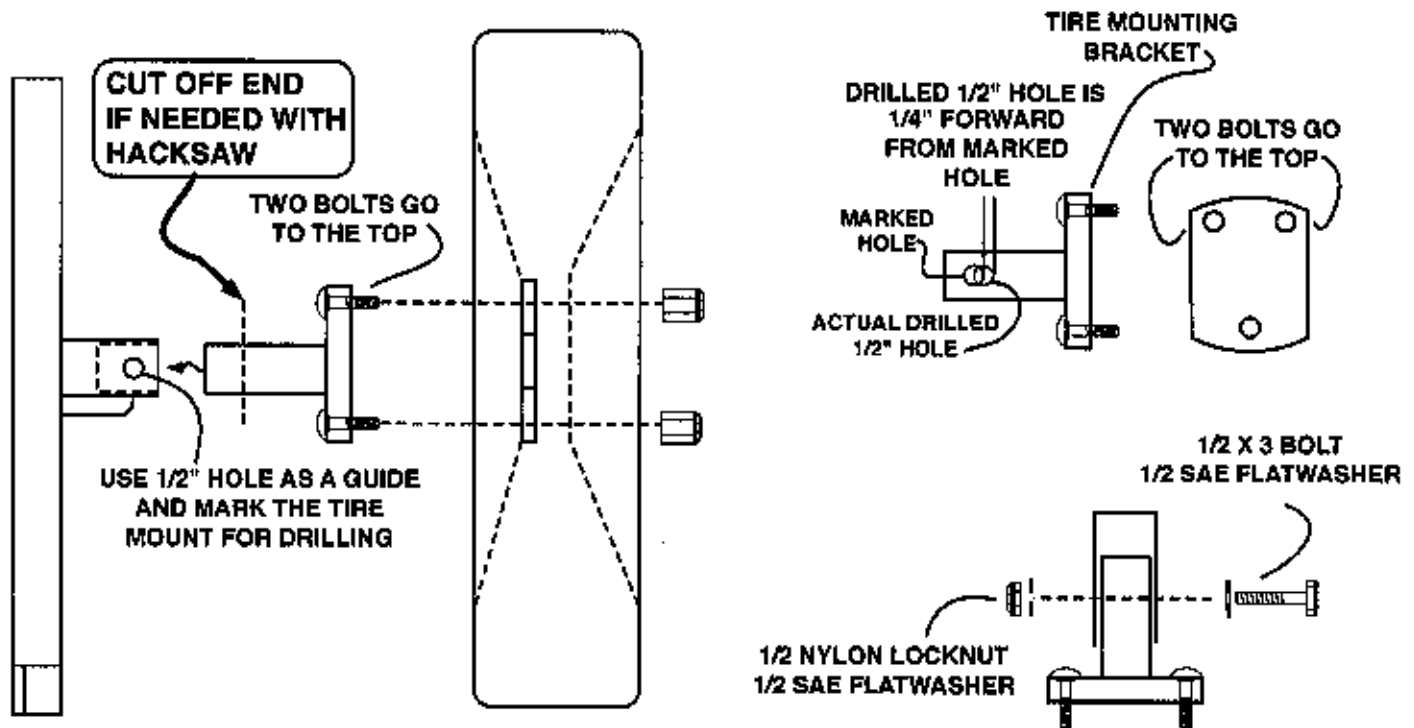

FIGURE K (MIDDLE STOP LIGHT INSTALLATION)



EXT SERIES BUMPER SYSTEM
PART# 71000
GENERAL ASSEMBLY DRAWING
TIRE MOUNTING BRACKET
(FITS 5 ON 4 1/2 BOLT PATTERN)
INSTALLATION INSTRUCTIONS



INSTALLATION INSTRUCTIONS

- 1 - INSTALL THE TIRE MOUNTING BRACKET TO THE WHEEL, SLIGHTLY TIGHTEN TO HOLD IN PLACE.
- 2 - WITH THE TWO WHEEL STUDS ON THE TOP, AS SHOWN, PICK UP THE TIRE AND WHEEL ASSEMBLY AND SLIDE THE SQUARE TIRE MOUNT INTO THE TIRE CARRIER.
- 3 - TIRE WIDTHS AND WHEEL OFF SETS VARY GREATLY. IF THE TIRE MOUNTING BRACKET BOTTOMS OUT IN THE RECEIVER BEFORE THE TIRE TOUCHES THE THREE UPRIGHTS, THEN THE TIRE BRACKET MUST BE TRIMMED SHORTER. (REFER TO DRAWING). THE END CAN BE CUT OFF WITH A BASIC HACKSAW WITH A GOOD BLADE.
- 4 - OPEN THE TIRE CARRIER TO GAIN ACCESS BEHIND THE TIRE, WITH THE TIRE TOUCHING THE THREE VERTICAL SUPPORT ARMS. USE THE HOLE IN THE TIRE MOUNT AS A GUIDE, MARK THE TIRE BRACKET FOR THE 1/2" HOLE. THE ACTUAL 1/2" HOLE IS DRILLED 1/4" FORWARD OF THE MARKED HOLE, REFER TO THE ABOVE DRAWING.
- 5 - REMOVE TIRE ASSEMBLY, REMOVE THE TIRE MOUNT BRACKET. MOVE MARKED HOLE ON THE MOUNT BRACKET 1/4" FORWARD, RE-MARK AND DRILL 1/2" DIA. HOLE IN TIRE MOUNT
- 6 - RE-INSTALL MOUNT BRACKET INTO TIRE CARRIER AND SECURE 1/2 X 3 BOLT, FLATWASHERS AND NYLON LOCKNUT
- 7 - INSTALL TIRE TO TIRE CARRIER