

TECHNICAL SPECIFICATION

Operating Voltage [V]	5 – 36v DC incl. residual ripple
Max current load [mA]	
Continuous	200 mA
Peak	200 mA
Voltage drop [V]	< 4.6v
Leakage current [mA]	< 0.8mA
Minimum load current [mA]	4mA
Permissible peak from the mains	Max 1000 V/10 ms at a source impedance of 20 K Ohm
Switching frequency [Hz]	2000 Hz
Switching status indication	Yellow LED
Protection grade	IP 67,
Operating temperature [oC]	-25 oC to + 80oC
Real sensing range [mm]	2mm +- 10%
Switching hysteresis [%/S _r]	≤ 5% of the sensing range
Correction factors	Mild steel = 1/ stainless steel 0.7/ brass 0.4/ Al 0.3/ copper 0.2
Switching point drift [%/S _r]	< +- 10% of S _r
Housing	Nickel-plated brass; POM; end cap: Makrolon

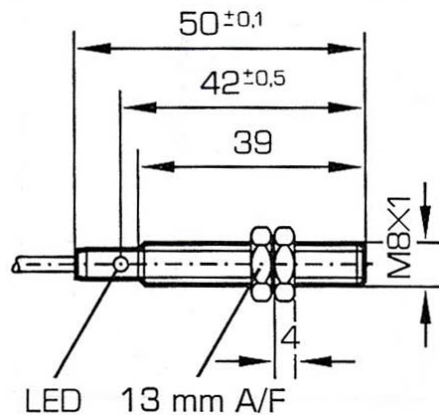

STACK
STACK
STACK

ST670

PROXIMITY SENSOR

USER INFORMATION

(ST541015-005)

(Auto Meter Ref. #2650-1749-77)

INSTALLATION

This sensor, when used for measuring vehicle speed, is best fitted to an undriven outside¹ wheel. The sensor produces pulses, which are then used to calculate the vehicle speed. The sensor is triggered by a number of 'Targets' (See Sensor Targets). It is essential to ensure that these devices are **NOT** mounted in a position close to any devices, or associated wiring, which are likely to interfere with the correct operation of the sensor.

Suggested Wiring Clearances	Min space ST670
Ignition HT & coil leads	100mm (4")
Radio transmitters and aerial leads	75mm (3")
Fast switching inductive loads like fuel injectors, hydraulic solenoids.	75mm (3")
Any powerful source of heat	Shield with reflective material

The ST670 connects into a STACK system via a four way, ITT Cannon Mini Sure Seal (MSS) connector. The following polarity is observed in all cases:

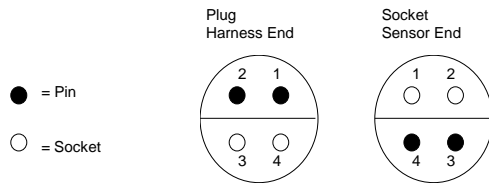

These terminals must be connected to the corresponding terminals of the selected input channel.

Pin Number	Signal Description
1	Signal from sensor
2	No connection
3	No connection
4	0v

The ST670 must therefore, be connected to **WS/P2/P3** on a ST872 harness: P2/P3 on a ST875: **C1** to **Cx** on any ST883 harnesses: or **WS** on a ST892 harness.

Sensor Targets.

The targets can be any suitable metallic object, which passes within range of the sensor tip. Iron or mild steel targets are preferred as they give a stronger signal to the sensor whilst aluminium, brass or copper targets give approximate one third of the range.

¹The outside wheel is on the left for clockwise, and on the right for anti-clockwise circuits.

It is **IMPORTANT** that the sensor and targets should be rigidly mounted so they do not move with vibration. Targets should be at least 10mm (5/8") diameter and stand 4mm (5/32") proud (Fig.1). Smaller targets can be used but this will reduce the range. Small aluminium, brass or copper targets will generally **NOT** work.

Nothing other than the targets should come within 6mm (1/4") of the end of the sensor. If the sensor mounting position is to be recessed, then a hollow of 24mm (15/16") diameter and at least 4mm (5/32") deep should be allowed around the sensor (Fig 2).

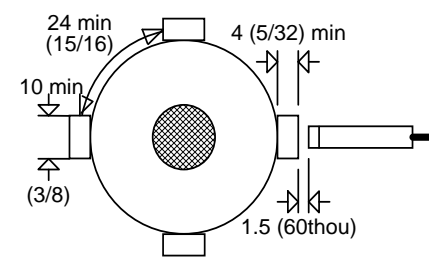

Fig. 1

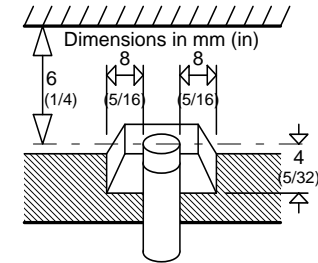

Fig. 2

Sensor Adjustment.

1. Connect the sensor to the system and turn on the power.
2. Assemble the first (rear) nut onto the sensor.
3. Insert the sensor into the mounting bracket hole and fit the front nut.
4. Rotate the wheel and move the sensor slowly forward by undoing the rear nut counter-clockwise until the light comes on for every target.
5. Undo the rear nut half a turn more.
6. Without rotating the sensor or rear nut, finger-tighten the front nut.
7. Tighten the rear nut with a 13mm AF spanner. Do **NOT** let the sensor rotate.
Do not over-tighten – half a flat of the nut should be sufficient.

The sensor has an in-built light (LED) which can be used to check that both the mechanical and electrical installations have been performed correctly. This light should be ON when a target is in front of the sensor.

Checks for correct installation and adjustment

1. Rotate the wheel and check that the light comes on for each target and goes off between each target.
2. Check that both the sensor and targets are rigidly mounted.
3. Check that the front nut does not cover any part of the sensing end.
4. **IMPORTANT** Check the gap between sensor and any of the targets is **NOT** less than 0.5mm (20thou). so there is no risk of the sensor touching targets in operation.

Please see the user manual of your system for setting the wheel circumference and pulses per revolution.