



413 West Elm Street • Sycamore, IL 60178
(866)248-6357 • (815)895-6786
www.autometer.com • service@autometer.com

INSTALLATION

- 1) If you are using a B&M Pro Stick shifter, the blue plunger extension must be installed on the tip of the air cylinder. Use the two supplied set screws to attach the extension. The plunger extension is not used on Hurst shifters.
- 2) Remove the existing mounting bolts that hold the shifter down to the floor and slide the AS2 mounting bracket underneath the shifter unit. There are two sets of mounting holes (one for Hurst and one for B&M); use the holes that align the air ram with the center of the shift lever handle. Replace the hold-down bolts and tighten. The AS2 mounting bracket will be sandwiched between the shifter and the floorboard.
- 3) Connect a 1/4" CO2 supply line to the solenoid quick connect fitting by pushing the line in to the fitting until it bottoms out. If you need to remove the air line, pull on the line while pushing in on the black lock ring.
- 4) Open the CO2 bottle and set the bottle regulator pressure from 60 to 100 psi.
- 5) Wire the air shifter as shown in the appropriate diagram on the reverse side.

ADJUSTMENT

The stroke of the air shifter's ram is set with shims located between the brass air ram and the shifter mounting bracket. To check and adjust the stroke of the plunger, follow this procedure:

With the car's engine NOT running, put the shift lever into low gear. If using a Dedenbear RPM-2 switch press and hold the "MANUAL UPSHIFT" button on the RPM switch. If using a different manufacturer's RPM switch or a shift timer, bypass the controller to make the shifter activate. The plunger should extend and shift the transmission. Make sure that the shifter is all the way into high gear; then check for clearance between the air ram plunger and the shift lever. If there is more than 1/16 inch, then remove one of the shim washers from the air ram and retest. Remove the second shim washer if needed.

MAKE SURE THAT THERE IS SOME CLEARANCE BETWEEN THE RAM AND THE SHIFT LEVER WHEN THE SHIFTER IS IN HIGH GEAR AND THE AIR RAM PLUNGER IS EXTENDED. If not, the air shifter will be damaged.

ADJUSTMENT

The stroke of the air shifter's ram is set with shims located between the brass air ram and the shifter mounting bracket. To check and adjust the stroke of the plunger, follow this procedure:

With the car's engine NOT running, put the shift lever into low gear. If using a Dedenbear RPM-2 switch press and hold the "MANUAL UPSHIFT" button on the RPM switch. If using a different manufacturer's RPM switch or a shift timer, bypass the controller to make the shifter activate. The plunger should extend and shift the transmission. Make sure that the shifter is all the way into high gear; then check for clearance between the air ram plunger and the shift lever. If there is more than 1/16 inch, then remove one of the shim washers from the air ram and retest. Remove the second shim washer if needed.

MAKE SURE THAT THERE IS SOME CLEARANCE BETWEEN THE RAM AND THE SHIFT LEVER WHEN THE SHIFTER IS IN HIGH GEAR AND THE AIR RAM PLUNGER IS EXTENDED. If not, the air shifter will be damaged.

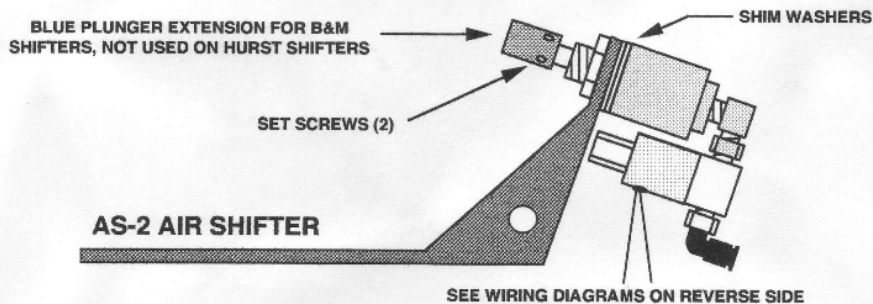

DEDENBEAR Products, Inc. warrants to the consumer that all DEDENBEAR Products purchased from an Authorized DEDENBEAR Reseller will be free from defects in material and workmanship for a period of twelve (12) months from date of the original purchase. Products that fail within this 12 month warranty period will be repaired or replaced at DEDENBEAR's option, when determined by DEDENBEAR that the product failed due to defects in material or workmanship. This warranty is limited to the repair or replacement of parts in the DEDENBEAR Product and the necessary labor done by DEDENBEAR to effect the repair or replacement of the DEDENBEAR product. In no event shall DEDENBEAR's cost to repair or replace a DEDENBEAR under this warranty exceed the original purchase price of the DEDENBEAR Product. Nor shall DEDENBEAR Products, Inc. be responsible for special, incidental or consequential damages or costs incurred due to the failure of a DEDENBEAR Product. This warranty applies only to the original purchaser of the DEDENBEAR Product and is non-transferable. This warranty also applies only to DEDENBEAR Products purchased from an Authorized DEDENBEAR Reseller. All implied warranties shall be limited in duration to the said 12 month warranty period. Breaking the instrument seal, improper use or installation, accident, water damage, abuse, unauthorized repairs or alterations voids this warranty. DEDENBEAR disclaims any liability for consequential damages due to the breach of any written or implied warranty on all products manufactured by DEDENBEAR Products, Inc.

FOR SERVICE SEND TO: DEDENBEAR PRODUCTS, INC 413 W. Elm St. Sycamore, IL 60178 USA (866) 248-6357
Email: service@autometer.com

CUSTOMER SERVICE & TECH. SUPPORT: (866)248-6357 Mon-Fri 8am-5pm CST

WIRING WITH DEDENBEAR RPM-2

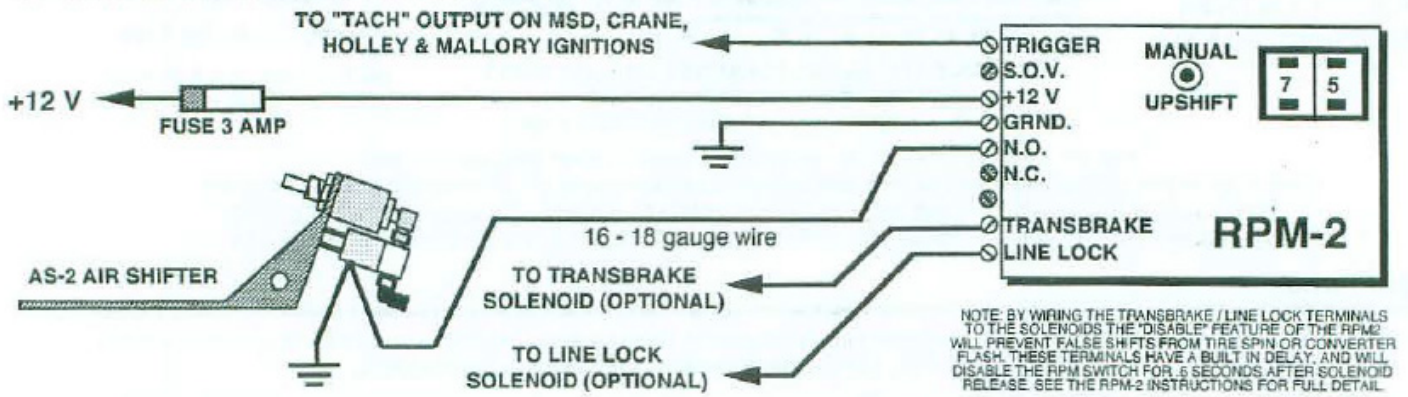

WIRING WITH DEDENBEAR BM-1, BM-2, CC-1, CC-2 OR CC-3

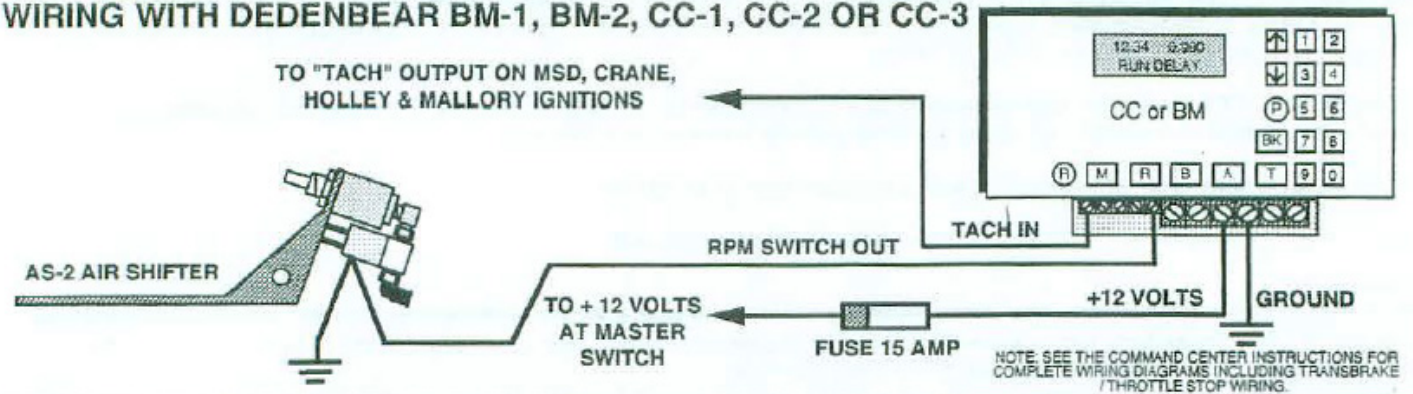

WIRING WITH MSD RPM SWITCH #8950

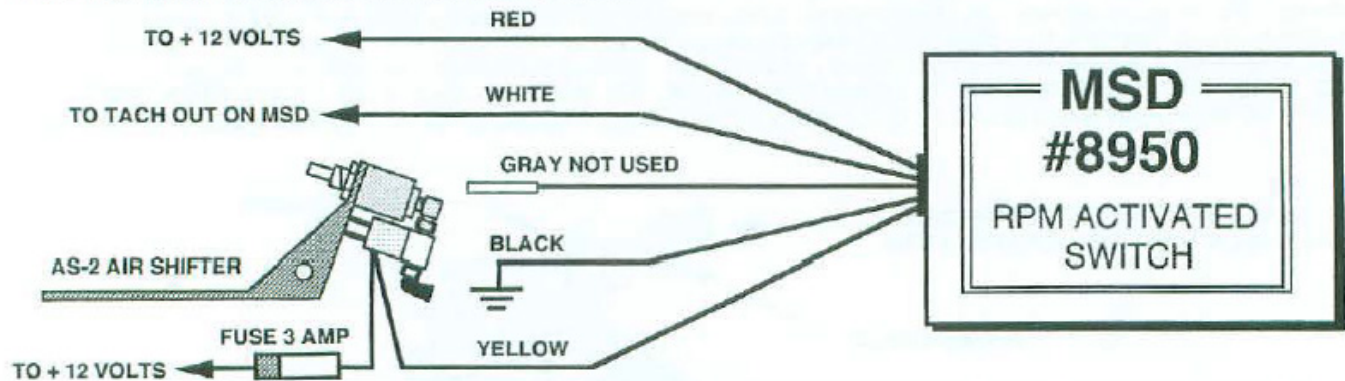

WIRING WITH MSD 7AL3 IGNITION

